

A4	THIRD ANGLE PROJECTION 	UNLESS OTHERWISE SPECIFIED:	NAME	DATE
		MATERIAL	DESIGN/ENGR C. O'BRIEN	2/2020
DIMENSIONS: INCHES (MILLIMETERS)		N/A	DRAWN W. SPIVEY	9/2020
			CHECKED R. JONES	9/2020
			REV A R JONES	12/2021
		DO NOT SCALE DRAWING	COMMENTS: REV A: NEW: SUSPENSION LAYOUT, COILOVERS, AXLE REINFORCEMENT	

Insurance Institute for Highway Safety  
988 Dairy Rd, Ruckersville, VA 22968 (434) 985-4600

# IIHS SIDE IMPACT CART

SCALE: 1:48 WEIGHT:1900 KG SHEET 1 of 66

5

4

3

2

1

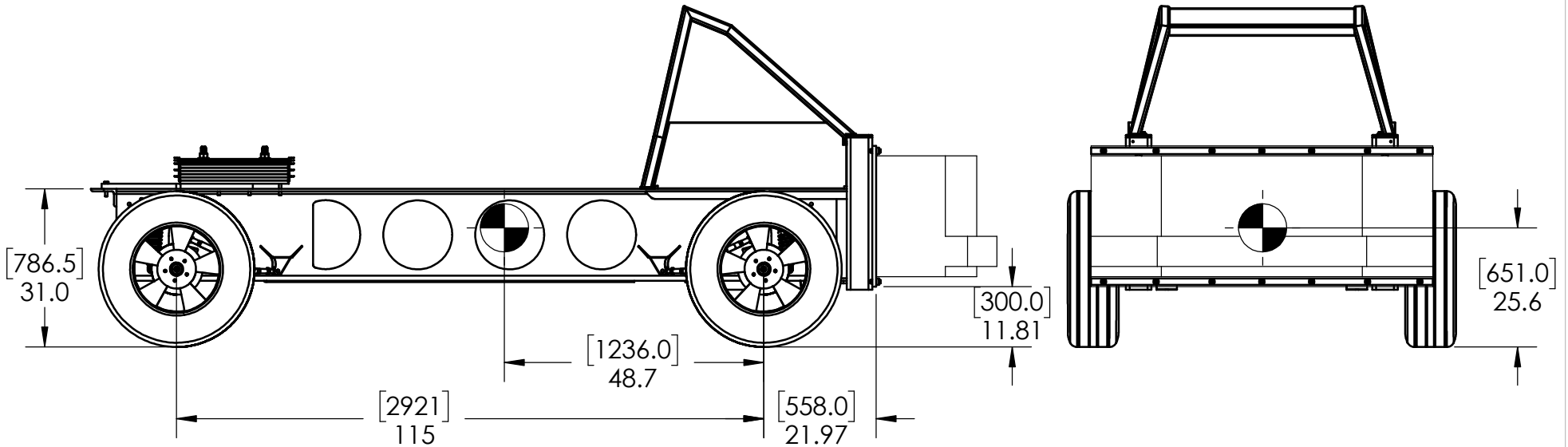
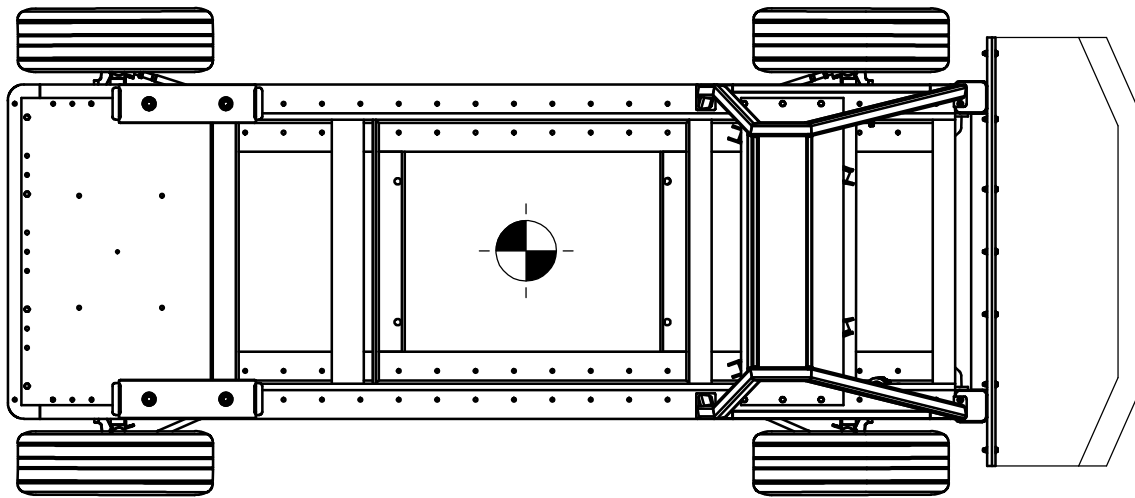

**DRAWING NOT  
FOR PRODUCTION USE**

A4	THIRD ANGLE PROJECTION	UNLESS OTHERWISE SPECIFIED:	NAME	DATE
		MATERIAL	DESIGN/ENGR	C. O'BRIEN 2/2020
DIMENSIONS: INCHES (MILLIMETERS)		N/A	DRAWN	W. SPIVEY 9/2020
			CHECKED	R. JONES 9/2020
			REV A	R. JONES 12/2021
			COMMENTS:	
			REV A: CG TARGETS, DIMENSIONS	
		DO NOT SCALE DRAWING		

Insurance Institute for Highway Safety		
988 Dairy Rd, Ruckersville, VA 22968 (434) 985-4600		
<b>IIHS SIDE IMPACT CART WITH BARRIER</b>		
SCALE: 1:30	WEIGHT: 1900 KG	SHEET 2 of 66

5

4

3

2

1

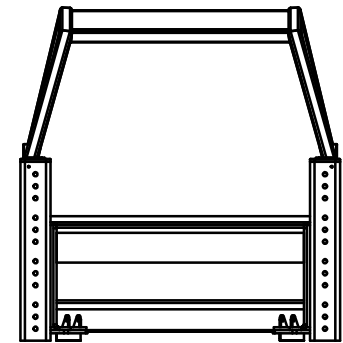
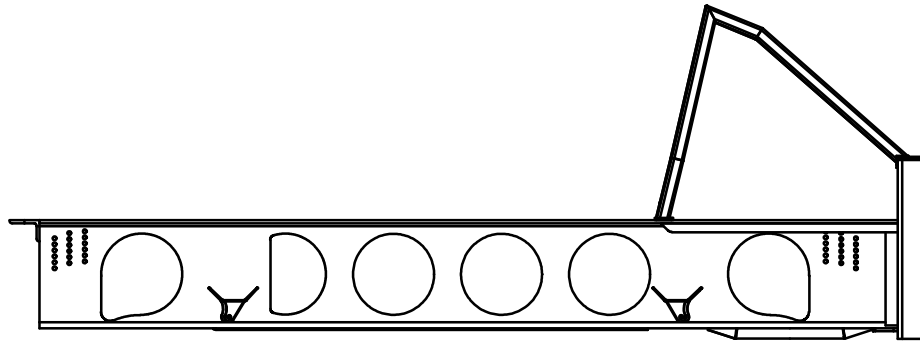
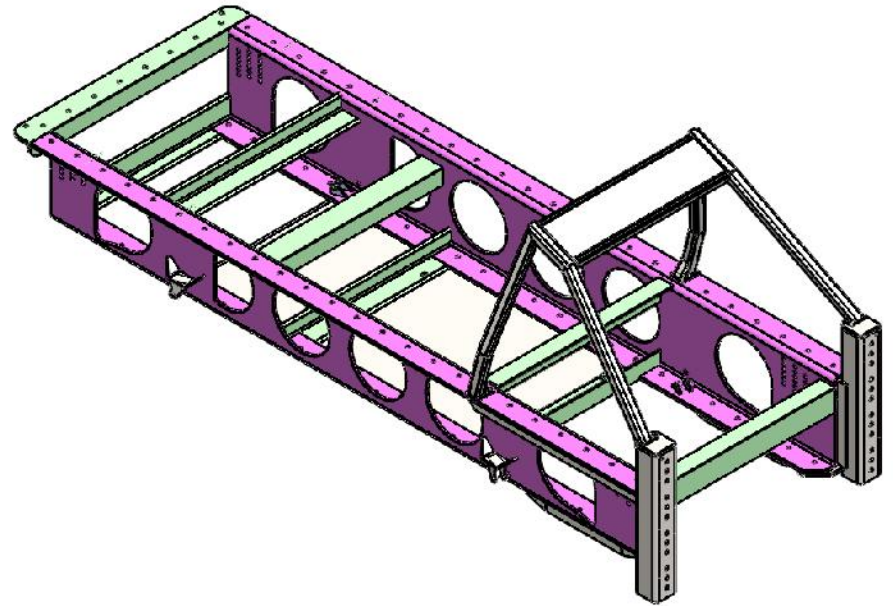
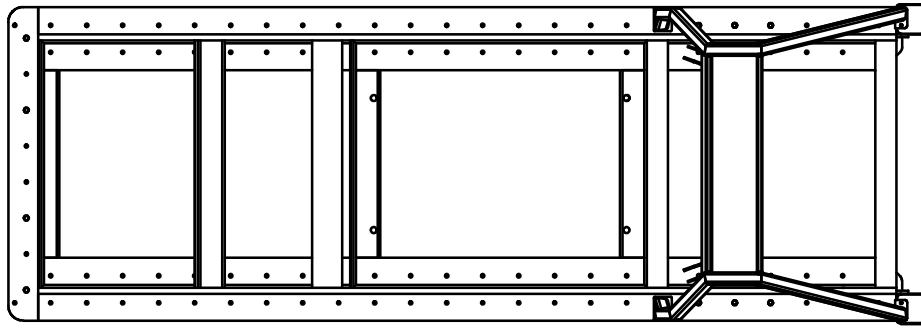

**DRAWING NOT  
FOR PRODUCTION USE**

A4	THIRD ANGLE PROJECTION	UNLESS OTHERWISE SPECIFIED:	NAME	DATE
		MATERIAL	DESIGN/ENGR C. O'BRIEN	2/2020
DIMENSIONS: INCHES (MILLIMETERS)		N/A	DRAWN W. SPIVEY	9/2020
			CHECKED R. JONES	9/2020
			REV A R. JONES	12/2021
			COMMENTS:	
		DO NOT SCALE DRAWING	REV A: UPDATE MODEL	

Insurance Institute for Highway Safety  
988 Dairy Rd, Ruckersville, VA 22968 (434) 985-4600

**WELDMENT COMPLETE**

SCALE: 1:32 WEIGHT: 780 KG SHEET 3 of 66

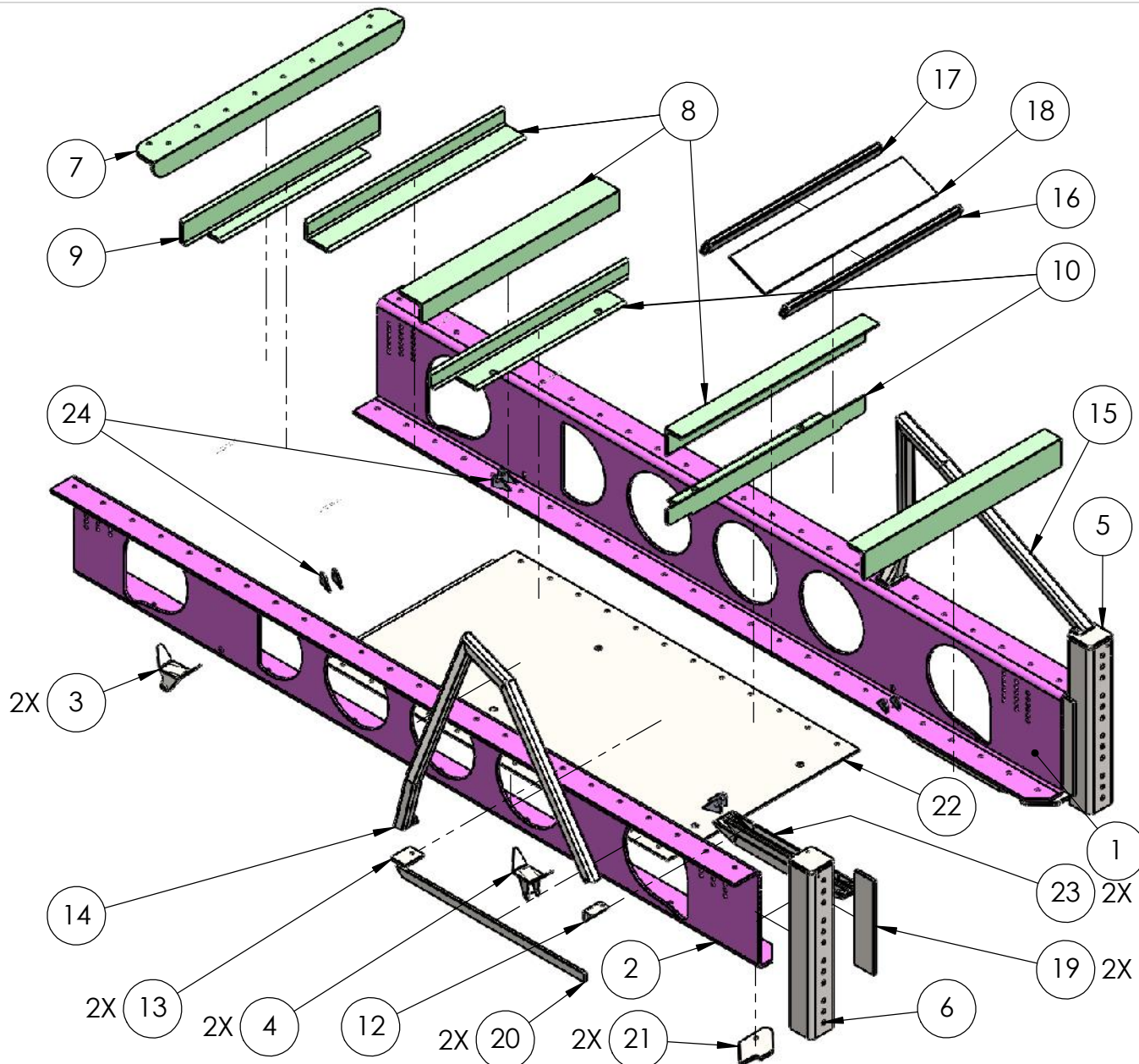

ITEM NO.	PART NUMBER	PAGE NUMBER	QTY.
1	Z CHANNEL, LEFT	6	1
2	Z CHANNEL, RIGHT	5	1
3	LOWER CONTROL ARM FRAME MOUNT ASSEMBLY, R REAR, L FRT	28	2
4	LOWER CONTROL ARM FRAME MOUNT ASSEMBLY, L REAR, R FRT	28	2
5	BARRIER STANCHION, LEFT	15	1
6	BARRIER STANCHION, RIGHT	15	1
7	REAR UPPER CROSSMEMBER	11	1
8	CHASSIS CROSSMEMBER SQUARE	8	4
9	CHASSIS CROSSMEMBER NOTCHED	10	1
10	CHASSIS CROSSMEMBER NOTCHED SHORT LEG	9	2
12	GREENHOUSE FRONT TAB	50	1
13	GREENHOUSE REAR TAB	51	1
14	GREENHOUSE TUBING, RIGHT	49	1
15	GREENHOUSE TUBING, LEFT	49	1
16	FRT CAM PLATE CROSSMEMBER	49	1
17	REAR CAM PLATE CROSSMEMBER	49	1
18	CAMERA MOUNT PLATE	52	1
19	BARRIER STANCHION FILLER PLATE	20	2
20	UPPER FLANGE REINFORCEMENT	26	2
21	LOWER BARRIER STANCHION GUSSET	25	2
22	FLOOR PAN ASSEMBLY	13	1
23	AXLE HOLE LWR CHANNEL REINFORCEMENT	22	2
24	UPPER CONTROL FRAME END TAB	32	8
89	HBOLT 0.5000-13X2.5X1.25-N		4
90	HBOLT 0.5000-13X3.5X1.25-N		6
91	HBOLT 0.5000-13X1.5X1.25-N		2

**DRAWING NOT FOR PRODUCTION USE**

<b>A4</b>	THIRD ANGLE PROJECTION	<b>UNLESS OTHERWISE SPECIFIED:</b>		
	DIMENSIONS: INCHES (MILLIMETERS)	MATERIAL	DESIGN/ENGR	NAME
		N/A	C. O'BRIEN	DATE
			W. SPIVEY	2/2020
			R. JONES	9/2020
			R. JONES	12/2021
			COMMENTS:	
			REV A: UPDATE MODEL, TABLE	
		DO NOT SCALE DRAWING		

Insurance Institute for Highway Safety  
988 Dairy Rd, Ruckersville, VA 22968 (434) 985-4600

**WELDMENTS EXPLODED VIEW**

SCALE: 1:24    WEIGHT: N/A    SHEET 4 of 66

5

4

3

2

1

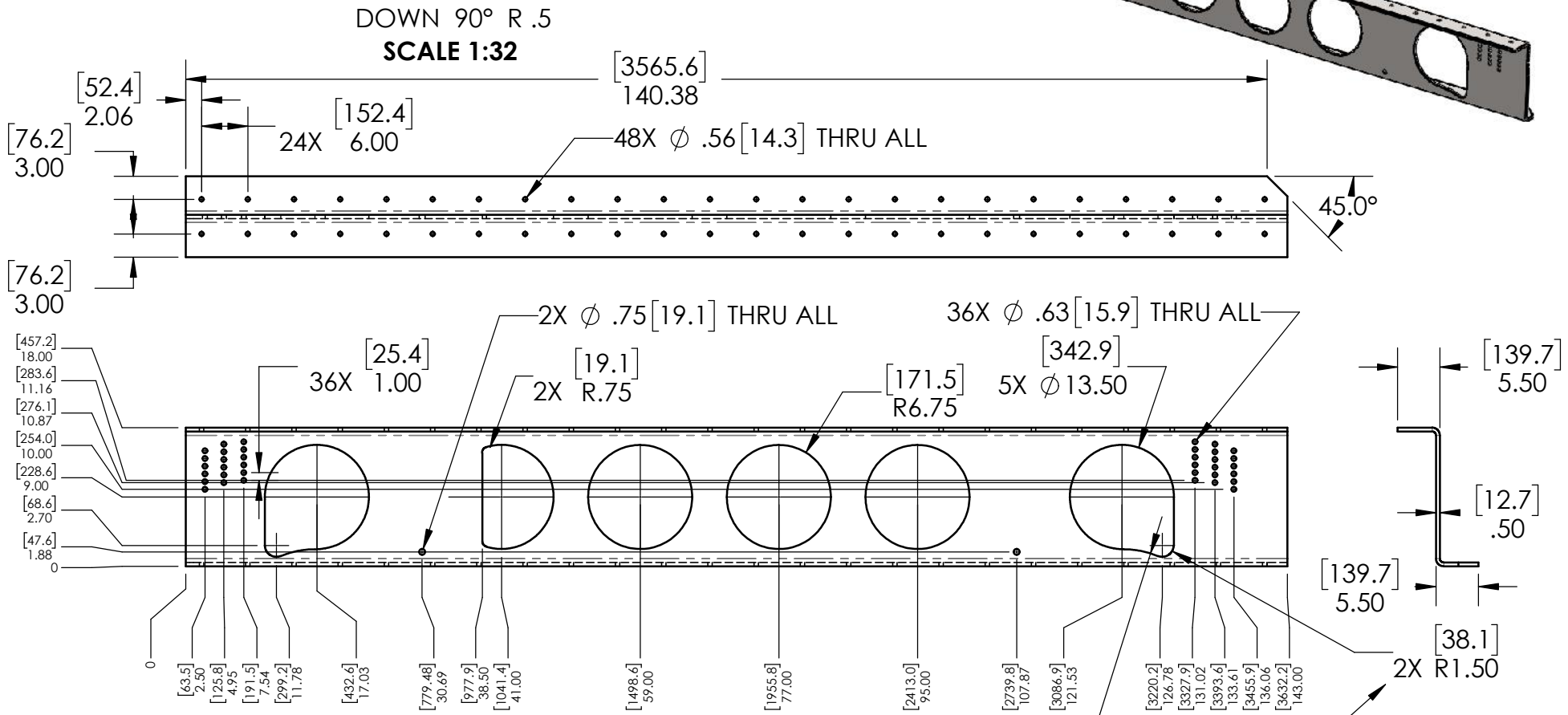
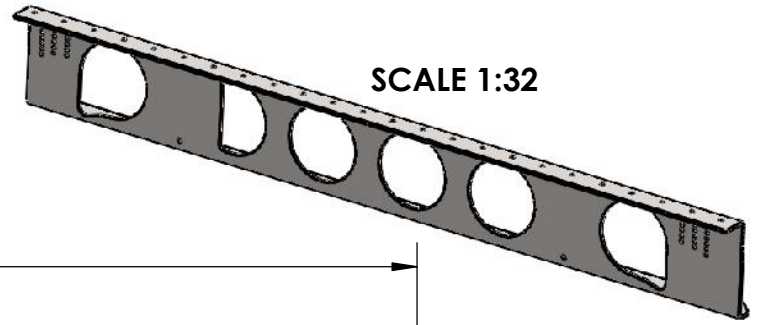
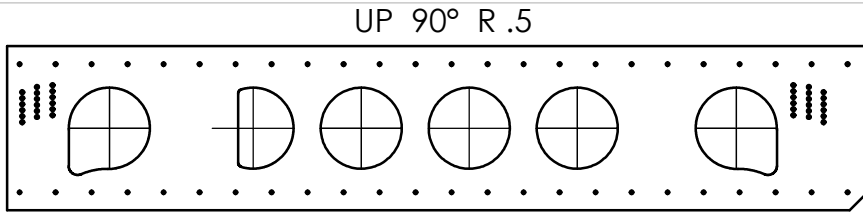

SCALE 1:20

2X R11.47  
2X R1.50  
CUT AFTER BENDING

**DRAWING NOT FOR PRODUCTION USE**

A4	THIRD ANGLE PROJECTION	UNLESS OTHERWISE SPECIFIED:	NAME	DATE
		MATERIAL	DESIGN/ENGR	C. O'BRIEN 1/3/2020
DIMENSIONS: INCHES [MILLIMETERS]		A572 GR50	DRAWN	R. JONES 2/6/2020
			REV A	R. JONES 12/2021
			COMMENTS:	
		DO NOT SCALE DRAWING	REV A: NO CHANGES	

Insurance Institute for Highway Safety		
988 Dairy Rd, Ruckersville, VA 22968 (434) 985-4600		
<b>RIGHT Z-CHANNEL</b>		
SCALE: VARIES	WEIGHT: 197 KG	SHEET 5 of 66

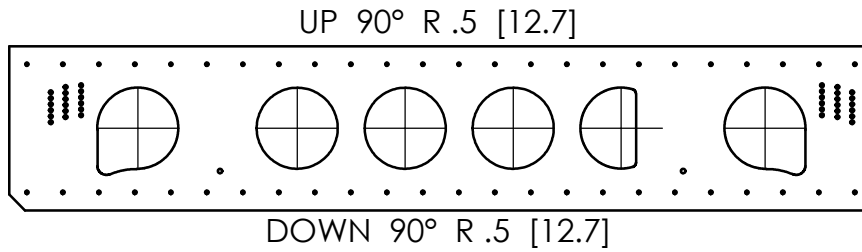

SCALE 1:32

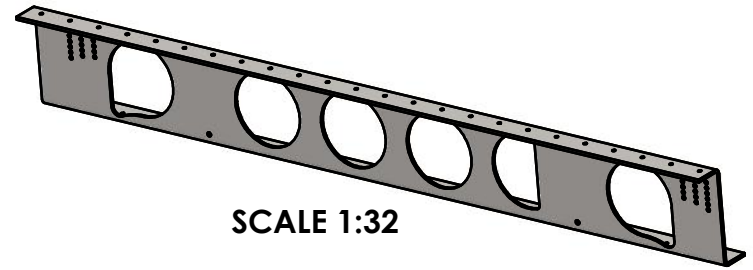

SCALE 1:32

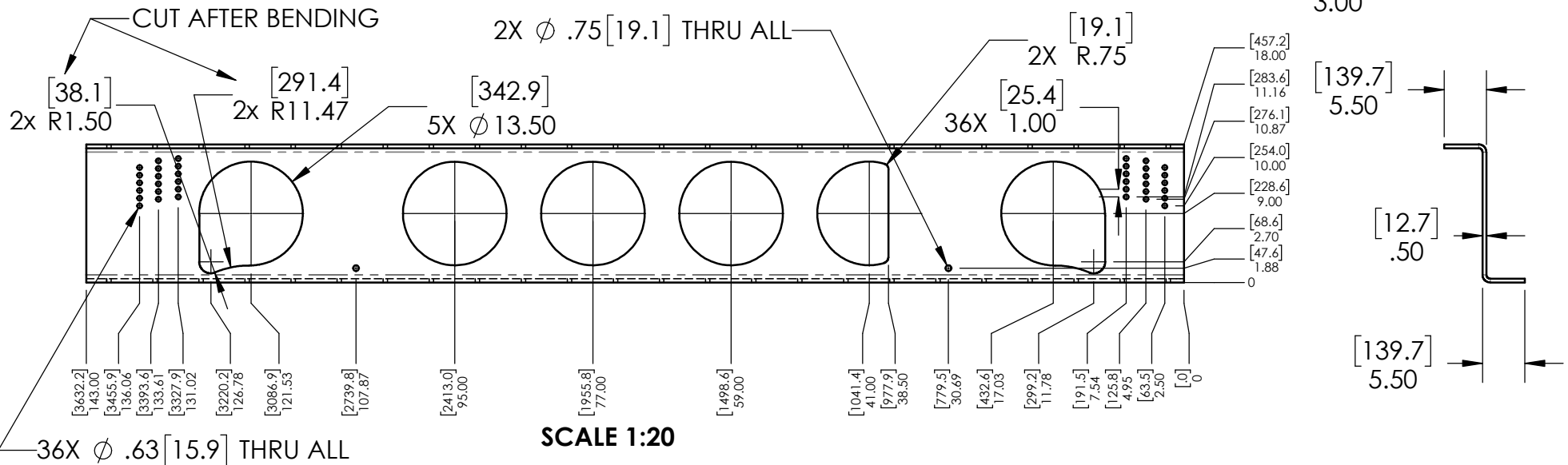
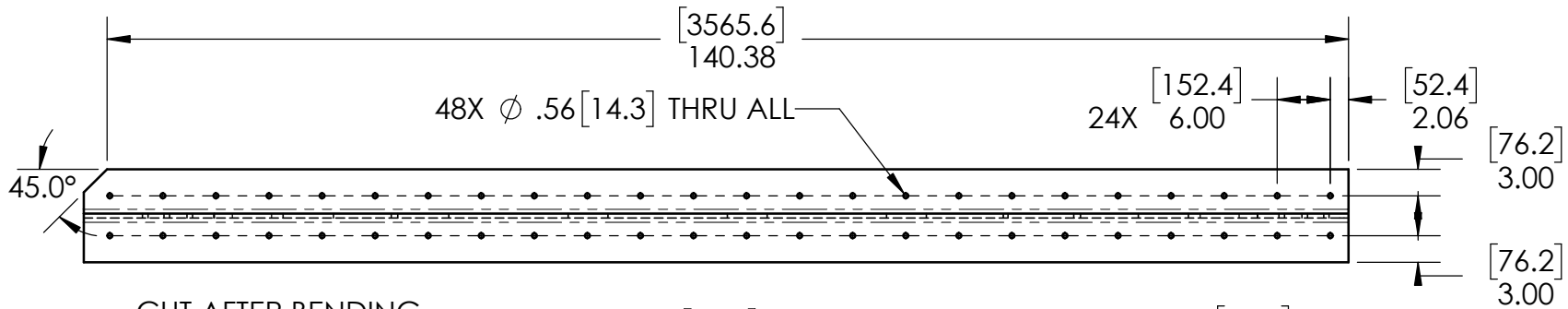

SCALE 1:20

**DRAWING NOT FOR PRODUCTION USE**

A4	THIRD ANGLE PROJECTION	UNLESS OTHERWISE SPECIFIED:	NAME	DATE
		MATERIAL	DESIGN/ENGR	C. O'BRIEN 1/3/2020
DIMENSIONS: INCHES (MILLIMETERS)		A572 GR50	DRAWN	R. JONES 2/4/2020
			REV A	R. JONES 12/2021
			COMMENTS:	
			REV A: NO CHANGES	
		DO NOT SCALE DRAWING		

Insurance Institute for Highway Safety  
988 Dairy Rd, Ruckersville, VA 22968 (434) 985-4600

**LEFT Z-CHANNEL**

SCALE: VARIES WEIGHT: 197 KG SHEET 6 of 66

5

4

3

2

1

ITEM NO.	PART NUMBER	PAGE NUMBER	QTY.
1	REAR UPPER CROSSMEMBER	11	1
2	CHASSIS CROSSMEMBER SQUARE	8	4
3	CHASSIS CROSSMEMBER NOTCHED	10	1
4	CHASSIS CROSSMEMBER NOTCHED SHORT LEG	9	2
87	HBOLT 0.5000-13X2.5X1.25-N		4
88	HBOLT 0.5000-13X1.5X1.25-N		6
89	HBOLT 0.5000-13X1.5X1.25-N		2

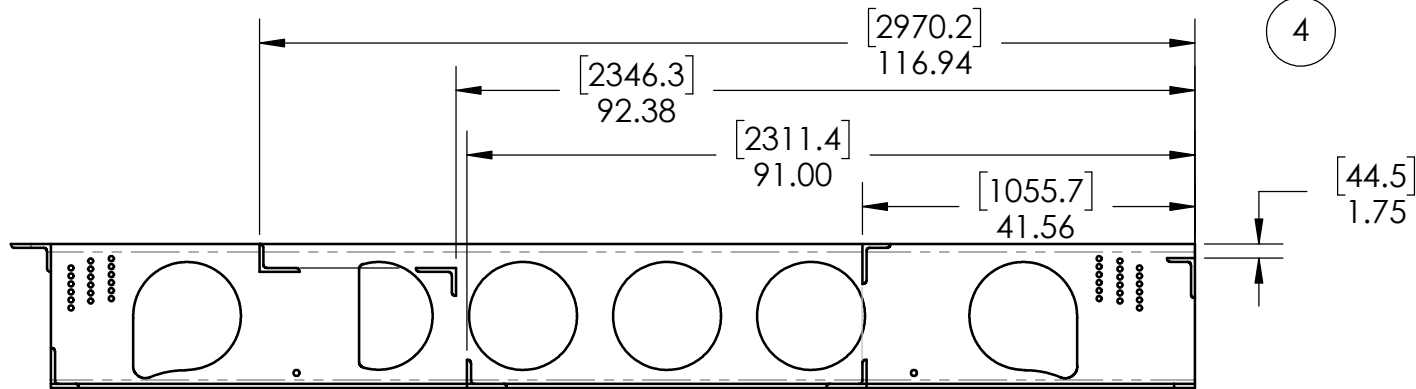
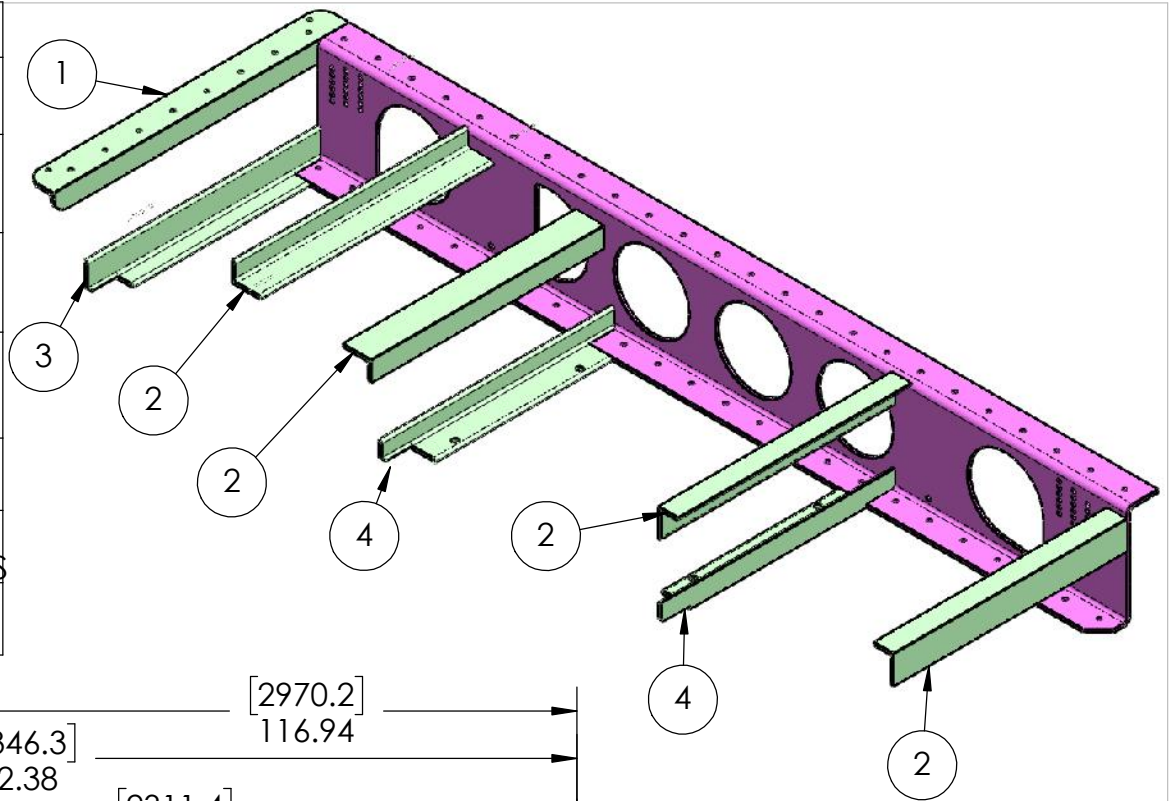

LEFT SIDE SHOWN, RIGHT SIDE SIMLIAR

**DRAWING NOT FOR PRODUCTION USE**

A4	THIRD ANGLE PROJECTION	UNLESS OTHERWISE SPECIFIED:	NAME	DATE
		MATERIAL	DESIGN/ENGR	C. O'BRIEN 2/2020
DIMENSIONS: INCHES (MILLIMETERS)		N/A	DRAWN	W. SPIVEY 9/2020
			CHECKED	R. JONES 9/2020
			REV A	R. JONES 12/2021
			COMMENTS:	
			REV A: NO CHANGES	
		DO NOT SCALE DRAWING		

Insurance Institute for Highway Safety  
988 Dairy Rd, Ruckersville, VA 22968 (434) 985-4600

## CHASSIS CROSSMEMBER PLACEMENT

SCALE: 1:24 WEIGHT: N/A SHEET 7 of 66

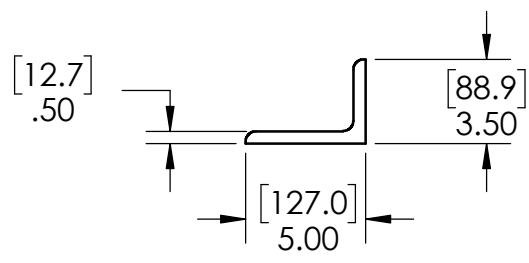
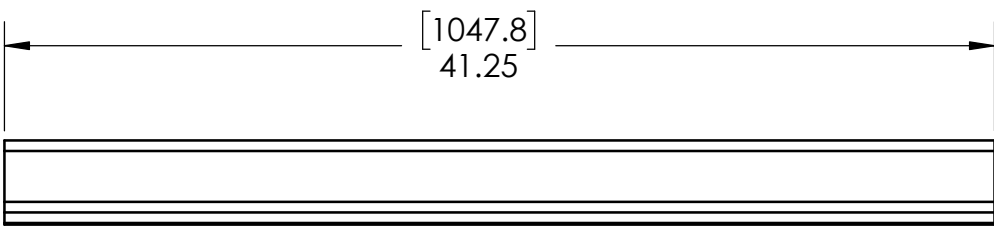
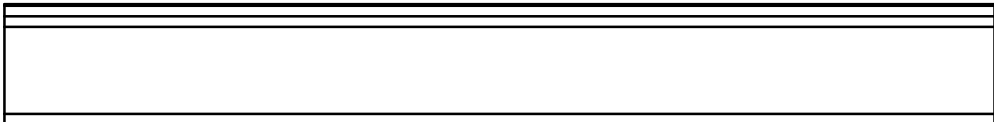
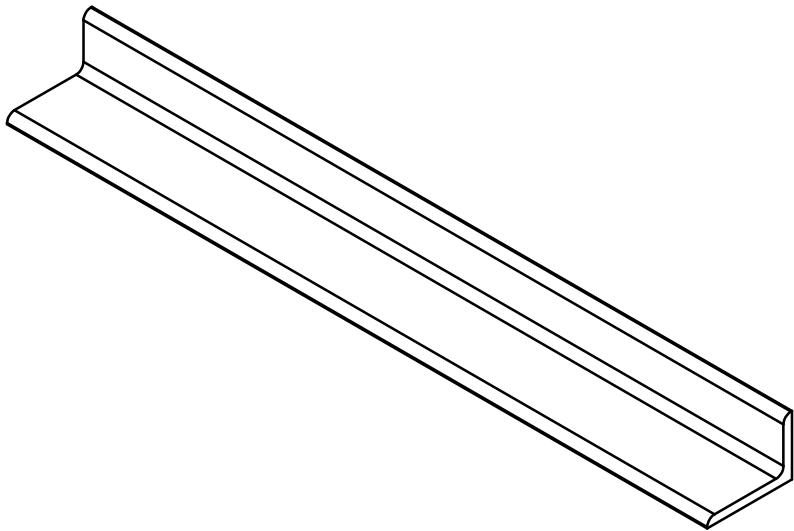

FROM 5X3.5X.5 ANGLE

**DRAWING NOT FOR PRODUCTION USE**

<b>A4</b>	THIRD ANGLE PROJECTION	UNLESS OTHERWISE SPECIFIED:	NAME	DATE
		MATERIAL	DESIGN/ENGR	
DIMENSIONS: INCHES (MILLIMETERS)		ASTM A36	C. O'BRIEN	2/2020
			DRAWN	W. SPIVEY
			CHECKED	R. JONES
			REV A	R. JONES
		COMMENTS:		
		DO NOT SCALE DRAWING	REV A: NO CHANGES	

Insurance Institute for Highway Safety		
988 Dairy Rd, Ruckersville, VA 22968 (434) 985-4600		
<b>CHASSIS CROSSMEMBER SQUARE</b>		
SCALE: 1:8	WEIGHT: 20 KG	SHEET 8 of 66



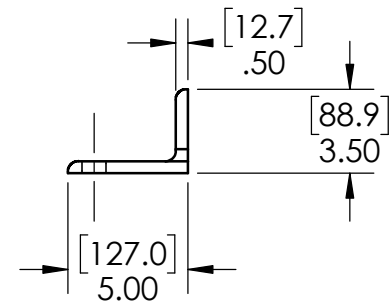
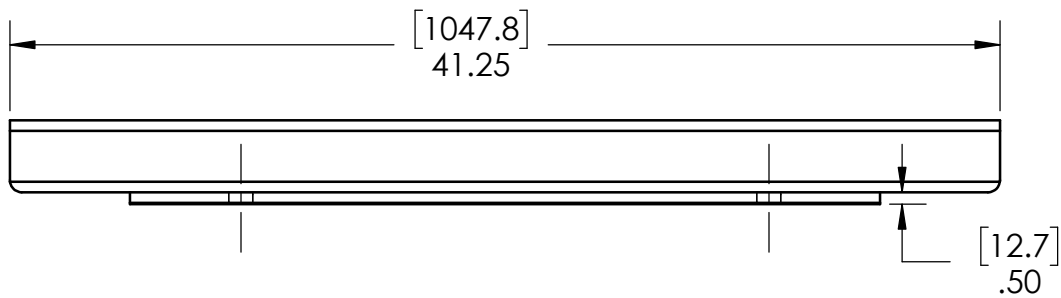
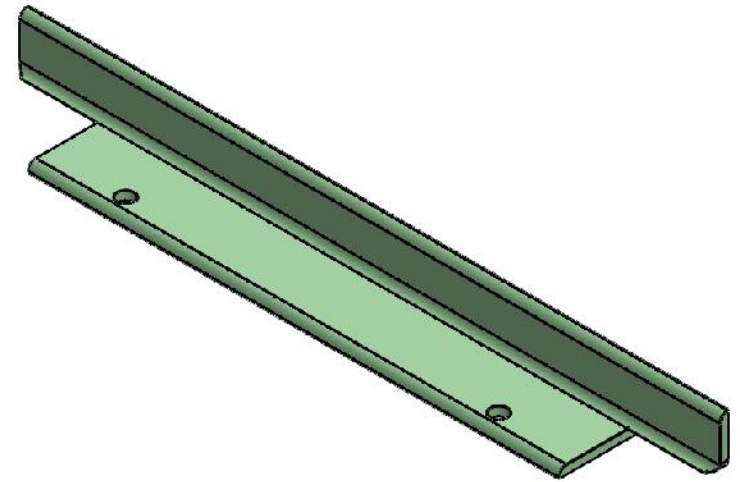
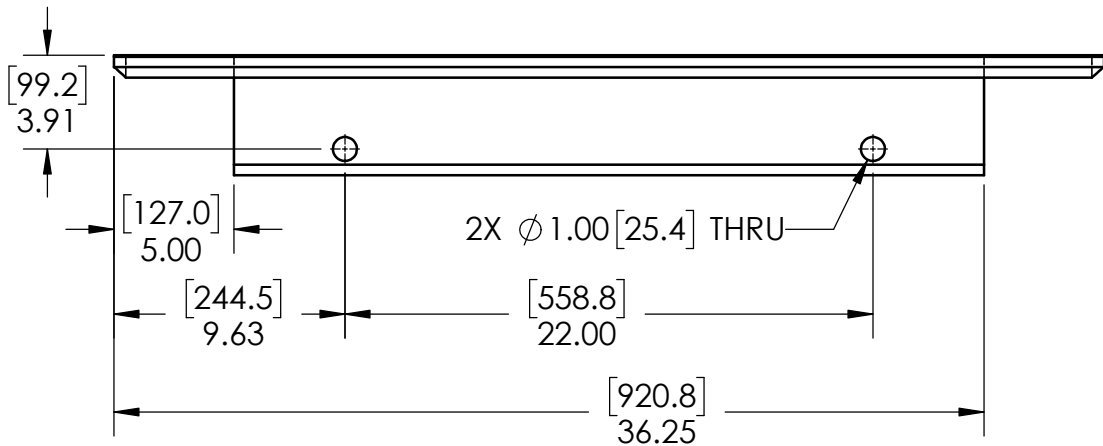

FROM 5X3.5X.5 ANGLE

**DRAWING NOT  
FOR PRODUCTION USE**

A4	THIRD ANGLE PROJECTION	UNLESS OTHERWISE SPECIFIED:	NAME	DATE
		MATERIAL	DESIGN/ENGR	C. O'BRIEN 2/2020
DIMENSIONS: INCHES (MILLIMETERS)		ASTM A36	DRAWN	W. SPIVEY 9/2020
			CHECKED	R. JONES 9/2020
			REV A	R. JONES 12/2021
			COMMENTS:	
		DO NOT SCALE DRAWING	REV A: NO CHANGES	

Insurance Institute for Highway Safety  
988 Dairy Rd, Ruckersville, VA 22968 (434) 985-4600

**CHASSIS CROSSMEMBER  
NOTCHED SHORT LEG**

SCALE: 1:8 | WEIGHT: 17 KG | SHEET 9 of 66

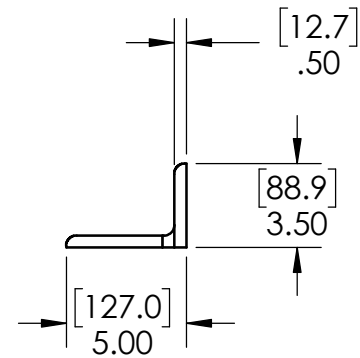
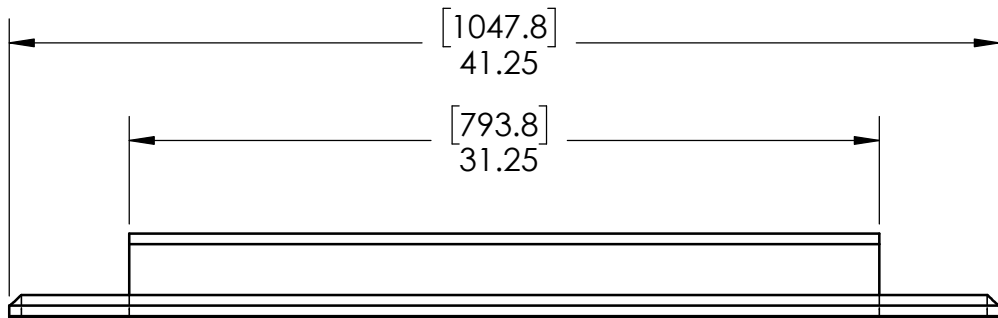
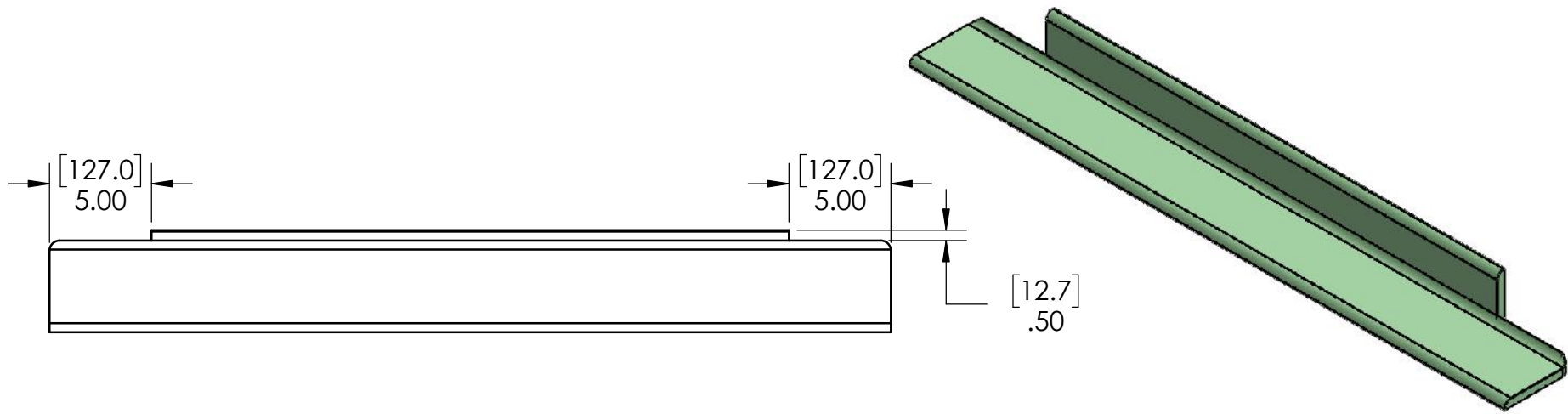

FROM 5X3.5X.5 ANGLE

**DRAWING NOT  
FOR PRODUCTION USE**

<b>A4</b>	THIRD ANGLE PROJECTION	UNLESS OTHERWISE SPECIFIED:	NAME	DATE
		MATERIAL	DESIGN/ENGR	
DIMENSIONS: INCHES (MILLIMETERS)		<b>ASTM A36</b>	C. O'BRIEN	2/2020
			DRAWN	W. SPIVEY
			CHECKED	R. JONES
			REV A	R. JONES
			COMMENTS:	
		DO NOT SCALE DRAWING	REV A: NO CHANGES	

Insurance Institute for Highway Safety  
988 Dairy Rd, Ruckersville, VA 22968 (434) 985-4600

**CHASSIS CROSSMEMBER  
NOTCHED**

SCALE: 1:8    WEIGHT: 18 KG    SHEET 10 of 66

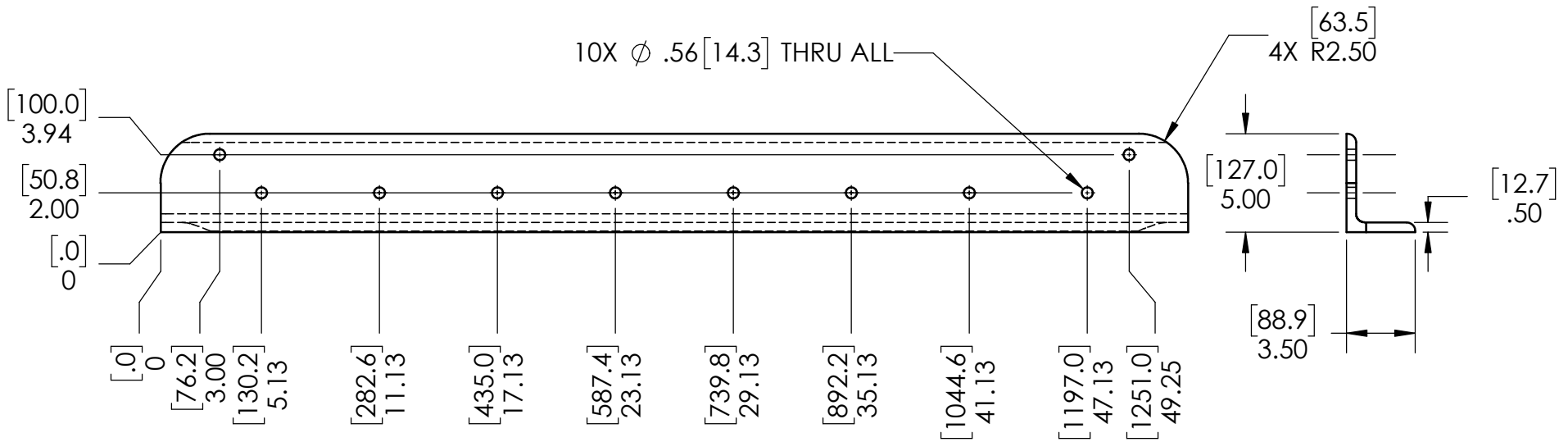
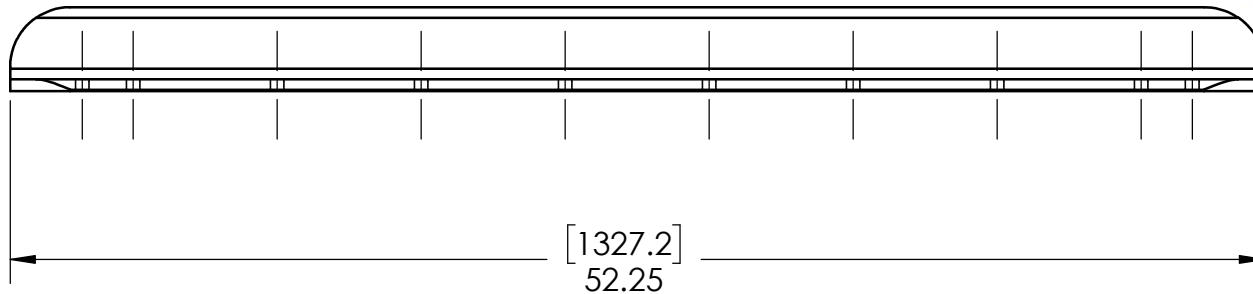
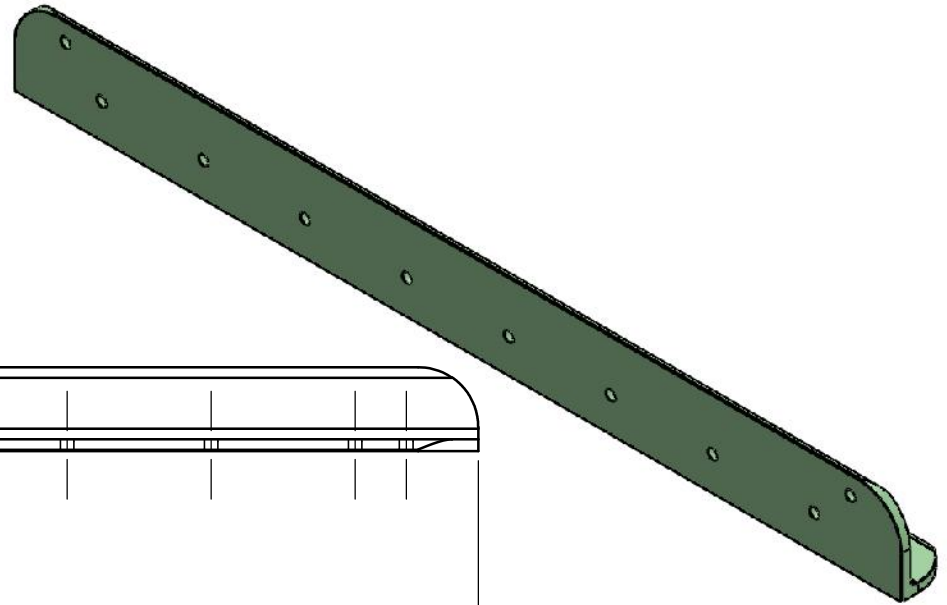

FROM 5X3.5X.5 ANGLE

**DRAWING NOT  
FOR PRODUCTION USE**

<b>A4</b>	THIRD ANGLE PROJECTION	UNLESS OTHERWISE SPECIFIED:	NAME	DATE
		MATERIAL	DESIGN/ENGR	C. O'BRIEN 2/2020
DIMENSIONS: INCHES (MILLIMETERS)		<b>ASTM A36</b>	DRAWN	W. SPIVEY 9/2020
			CHECKED	R. JONES 9/2020
			<b>REV A</b>	R. JONES 12/2021
			COMMENTS:	
		DO NOT SCALE DRAWING	REV A: NO CHANGES	

Insurance Institute for Highway Safety  
988 Dairy Rd, Ruckersville, VA 22968 (434) 985-4600

**REAR UPPER  
CROSSMEMBER**

SCALE: 1:8 WEIGHT: 26 kg SHEET 11 of 66

5

4

3

2

1

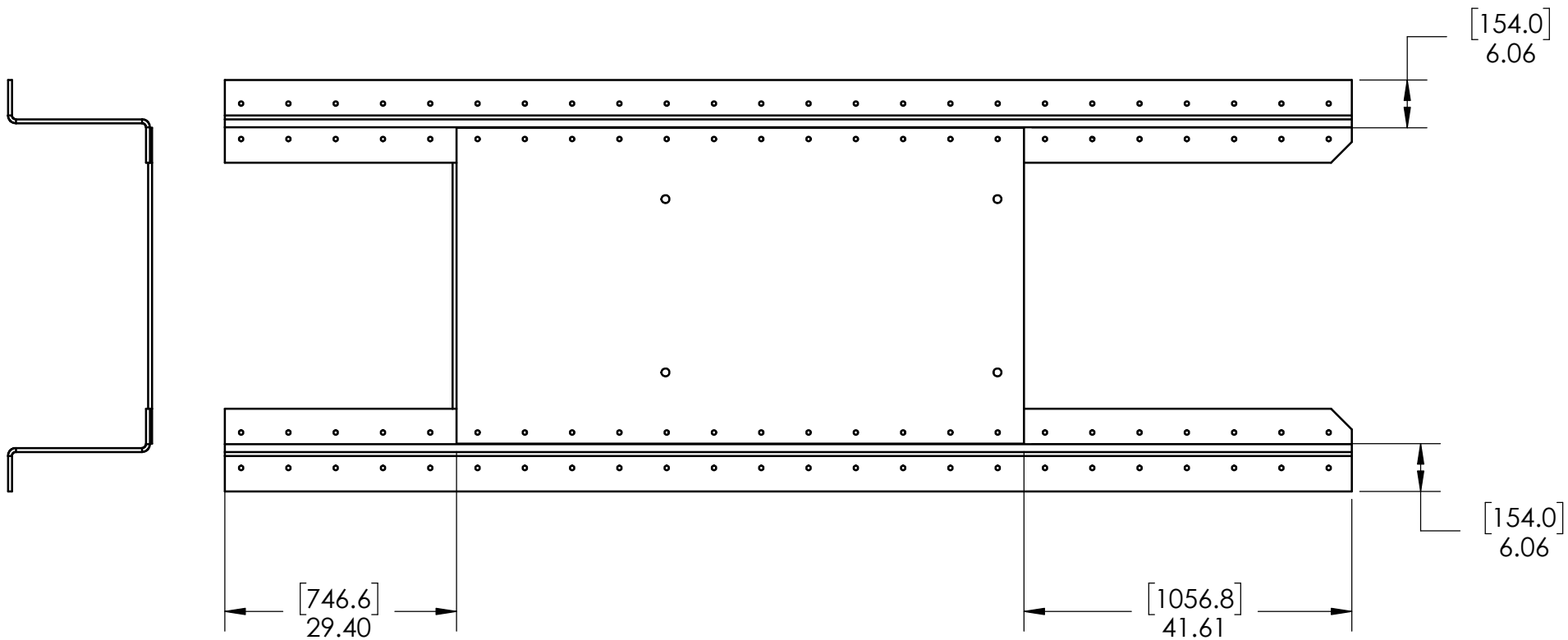

**DRAWING NOT  
FOR PRODUCTION USE**

<b>A4</b>	THIRD ANGLE PROJECTION	UNLESS OTHERWISE SPECIFIED:	NAME	DATE
		MATERIAL	DESIGN/ENGR	
DIMENSIONS: INCHES (MILLIMETERS)		N/A	C. O'BRIEN	2/2020
			DRAWN	W. SPIVEY
			CHECKED	R. JONES
			REV A	R. JONES
		COMMENTS:	12/2021	
		REV A: NO CHANGES		
		DO NOT SCALE DRAWING		

Insurance Institute for Highway Safety  
988 Dairy Rd, Ruckersville, VA 22968 (434) 985-4600

## CHASSIS FLOORPAN PLACEMENT

SCALE: 1:20 | WEIGHT: N/A | SHEET 12 of 66

5

4

3

2

1

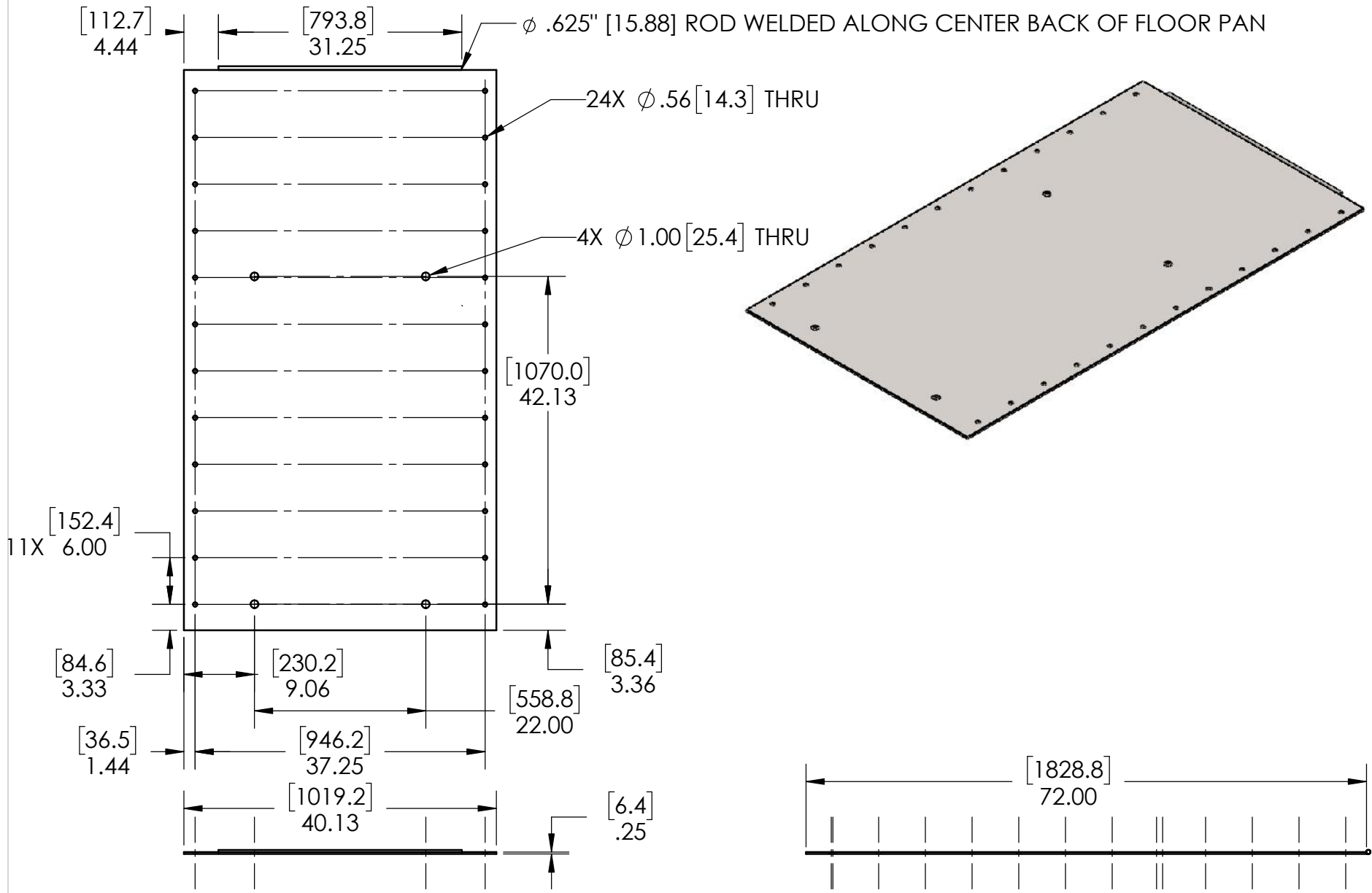

**DRAWING NOT FOR PRODUCTION USE**

<b>A4</b>	THIRD ANGLE PROJECTION	UNLESS OTHERWISE SPECIFIED:	NAME	DATE
		MATERIAL	DESIGN/ENGR	C. O'BRIEN 2/2020
DIMENSIONS: INCHES (MILLIMETERS)		<b>ASTM A36</b>	DRAWN	W. SPIVEY 9/2020
			CHECKED	R. JONES 9/2020
			<b>REV A</b>	R. JONES 12/2021
			COMMENTS:	
			REV A: NO CHANGES	
		DO NOT SCALE DRAWING		

Insurance Institute for Highway Safety		
988 Dairy Rd, Ruckersville, VA 22968 (434) 985-4600		
<b>CHASSIS FLOORPAN ASSEMBLY</b>		
SCALE: 1:18	WEIGHT: 92 KG	SHEET 13 of 66

ITEM NO.	PART NUMBER	PAGE NUMBER	QTY.
1	Z CHANNEL	5	1
2	BARRIER STANCHION	15	2
3	BARRIER STANCHION FILLER PLATE	20	2
87	HBOLT 0.5000-13x2.5x1.25-N		4
88	HBOLT 0.5000-13x3.5x1.25-N		6
89	HBOLT 0.5000-13x1.5x1.25-N		2

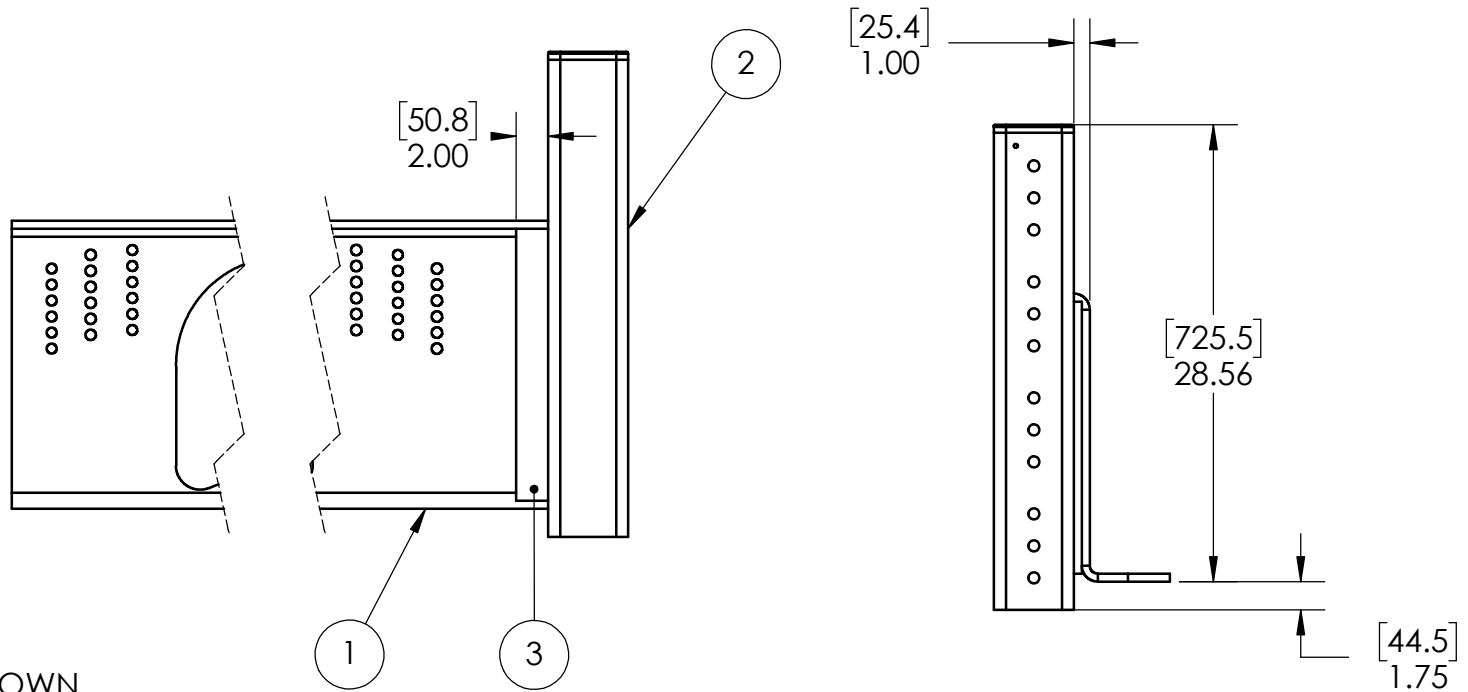
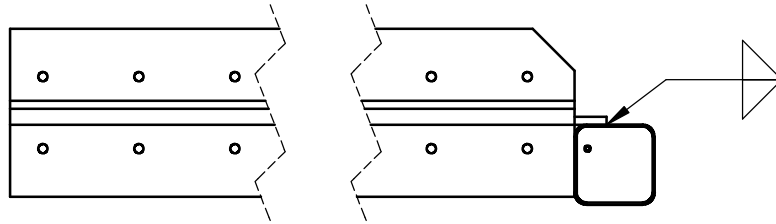

RIGHT SIDE SHOWN,  
LEFT SIDE OPPOSITE

**DRAWING NOT  
FOR PRODUCTION USE**

<b>A4</b>	THIRD ANGLE PROJECTION	UNLESS OTHERWISE SPECIFIED:	NAME	DATE
		MATERIAL	DESIGN/ENGR	
DIMENSIONS: INCHES (MILLIMETERS)		N/A	C. O'BRIEN	2/2020
			DRAWN	W. SPIVEY
			CHECKED	R. JONES
			REV A	R. JONES
			COMMENTS:	12/2021
			REV A: ADD WELD	
		DO NOT SCALE DRAWING		

Insurance Institute for Highway Safety  
988 Dairy Rd, Ruckersville, VA 22968 (434) 985-4600

## BARRIER STANCHION PLACEMENT

SCALE: 1:12 WEIGHT: N/A SHEET 14 of 66

ITEM NO.	PART NUMBER	PAGE NUMBER	QTY.
1	BARRIER STANCHION TUBE	16	1
2	BARRIER STANCHION END CAP	17	1
3	BARRIER STANCHION BOTTOM PLATE	19	1
4	BARRIER STANCHION HOLE REINFORCEMENT	18	1

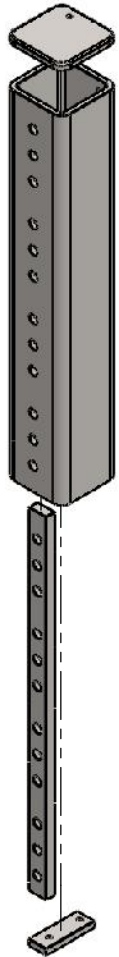
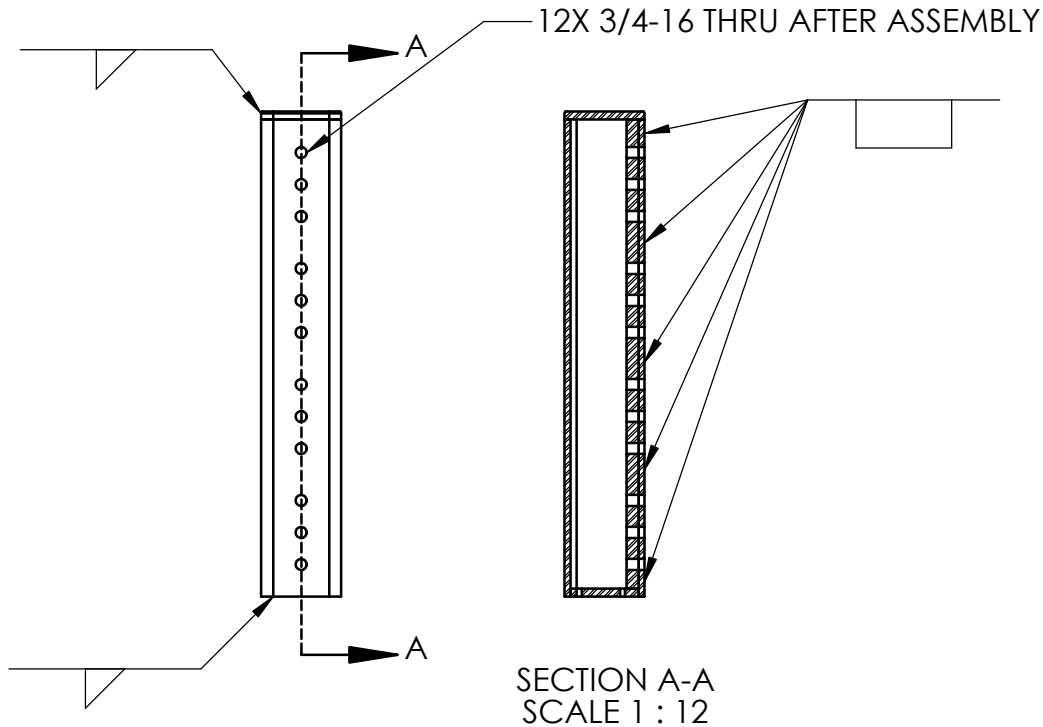
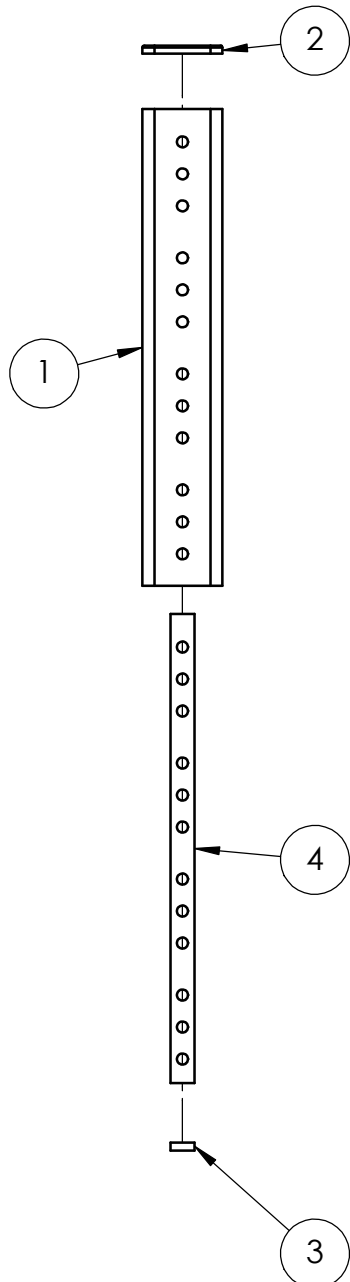

**DRAWING NOT  
FOR PRODUCTION USE**

<b>A4</b>	THIRD ANGLE PROJECTION	UNLESS OTHERWISE SPECIFIED:	NAME	DATE
		MATERIAL	DESIGN/ENGR	C. O'BRIEN 2/2020
DIMENSIONS: INCHES (MILLIMETERS)		N/A	DRAWN	W. SPIVEY 9/2020
			CHECKED	R. JONES 9/2020
			REV A	R. JONES 12/2021
			COMMENTS:	
			REV A: ADD WELDS	
		DO NOT SCALE DRAWING		

Insurance Institute for Highway Safety  
988 Dairy Rd, Ruckersville, VA 22968 (434) 985-4600

## BARRIER STANCHION ASSEMBLY

SCALE: 1:12 | WEIGHT: 30 KG | SHEET 15 of 66

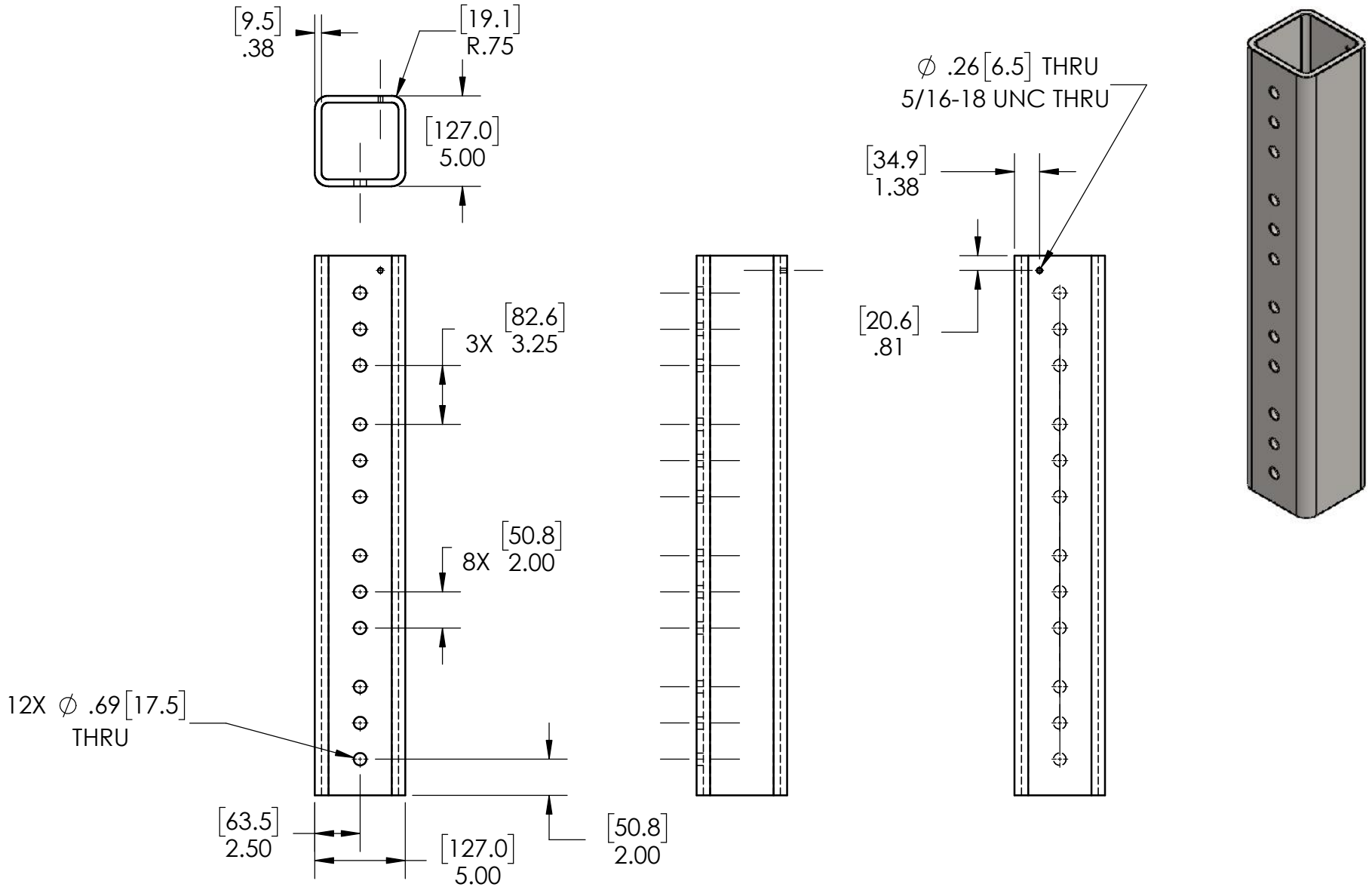

FROM 5 X 5 X .375 TUBE

**DRAWING NOT FOR PRODUCTION USE**

<b>A4</b>	THIRD ANGLE PROJECTION	<b>UNLESS OTHERWISE SPECIFIED:</b>	NAME	DATE
		MATERIAL	DESIGN/ENGR	C. O'BRIEN 2/2020
DIMENSIONS: INCHES (MILLIMETERS)		<b>ASTM A500</b>	DRAWN	W. SPIVEY 9/2020
			CHECKED	R. JONES 9/2020
			REV A	R. JONES 12/2021
			COMMENTS:	
			REV A: NO CHANGES	
		DO NOT SCALE DRAWING		

Insurance Institute for Highway Safety		
988 Dairy Rd, Ruckersville, VA 22968 (434) 985-4600		
<b>BARRIER STANCHION TUBE</b>		
SCALE: 1:8	WEIGHT: 24 KG	SHEET 16 of 66

5

4

3

2

1



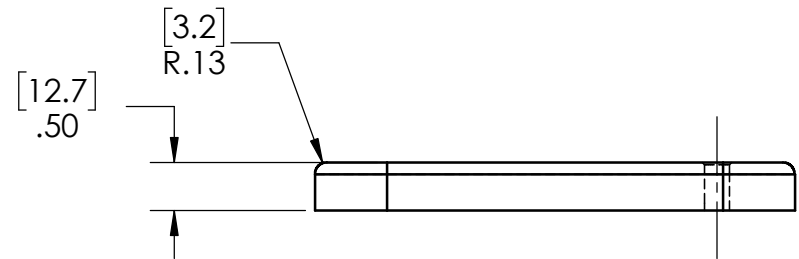
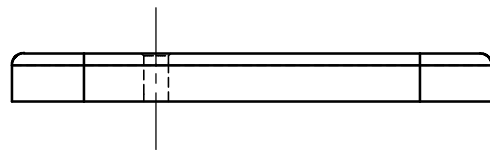
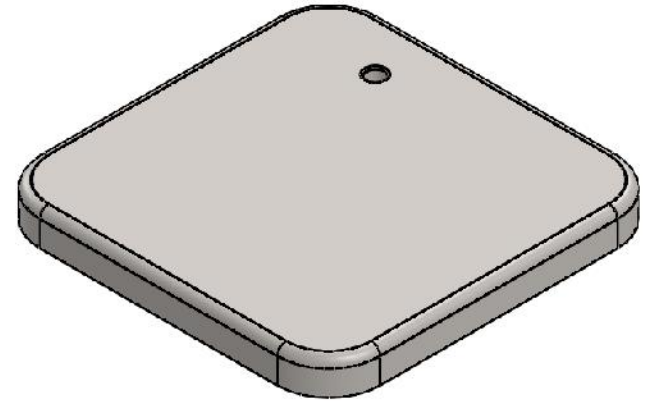
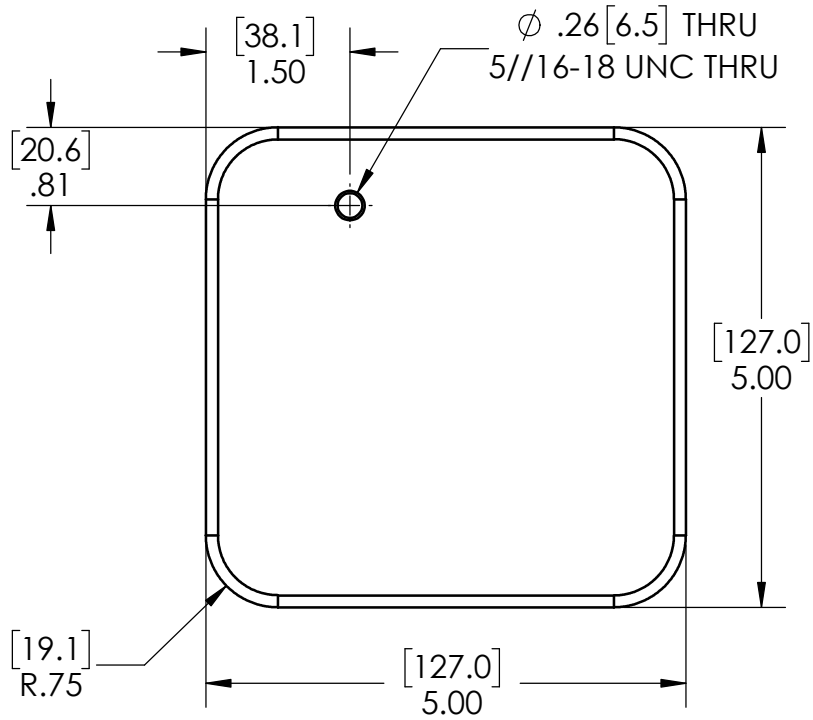

**DRAWING NOT FOR PRODUCTION USE**

A4	THIRD ANGLE PROJECTION	UNLESS OTHERWISE SPECIFIED:	NAME	DATE
		MATERIAL	DESIGN/ENGR	C. O'BRIEN 2/2020
DIMENSIONS: INCHES (MILLIMETERS)		ASTM A36	DRAWN	W. SPIVEY 9/2020
			CHECKED	R. JONES 9/2020
			REV A	R. JONES 12/2021
			COMMENTS:	
		DO NOT SCALE DRAWING	REV A: NO CHANGES	

Insurance Institute for Highway Safety		
988 Dairy Rd, Ruckersville, VA 22968 (434) 985-4600		
<b>BARRIER STANCHION END CAP</b>		
SCALE: 1:2	WEIGHT: 1.5 KG	SHEET 17 of 66

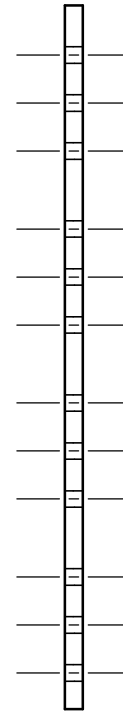
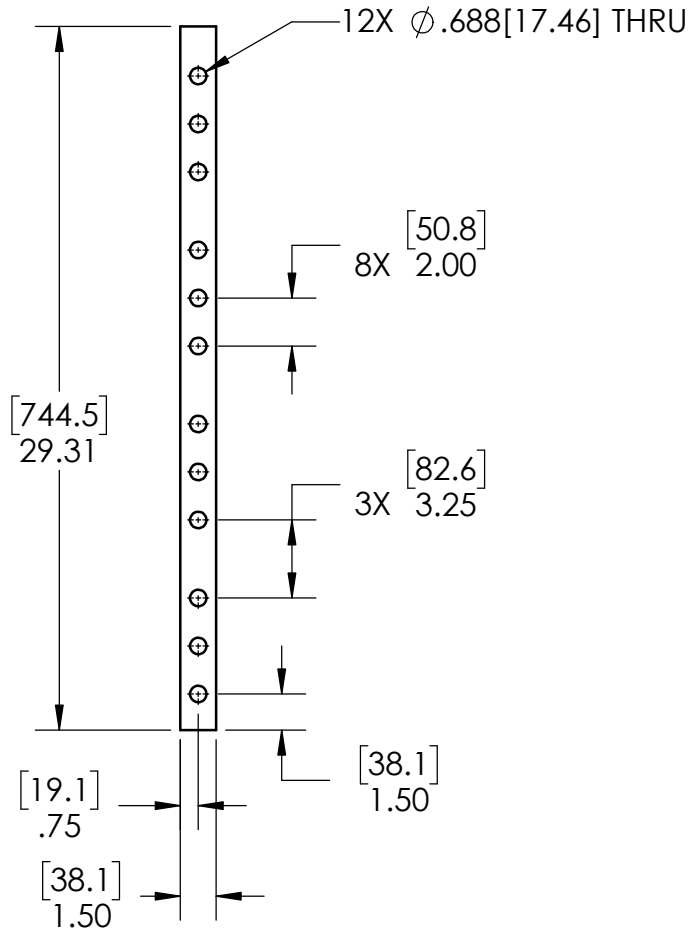
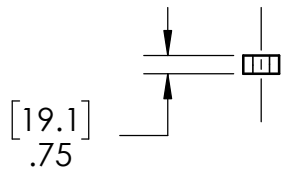

FROM .75X1.5 BAR

**DRAWING NOT  
FOR PRODUCTION USE**

<b>A4</b>	THIRD ANGLE PROJECTION	<b>UNLESS OTHERWISE SPECIFIED:</b>	NAME	DATE
		MATERIAL	DESIGN/ENGR	C. O'BRIEN 2/2020
DIMENSIONS: INCHES (MILLIMETERS)		<b>ASTM A36</b>	DRAWN	W. SPIVEY 9/2020
			CHECKED	R. JONES 9/2020
			REV A	R. JONES 12/2021
			COMMENTS:	
			REV A: NO CHANGES	
		DO NOT SCALE DRAWING		

Insurance Institute for Highway Safety  
988 Dairy Rd, Ruckersville, VA 22968 (434) 985-4600

# BARRIER STANCHION HOLE REINFORCEMENT

SCALE: 1:8 | WEIGHT: 3.8 KG | SHEET 18 of 66

2X 3/8-16 UNC TAPPED HOLE

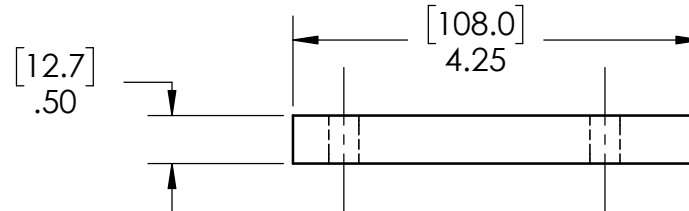
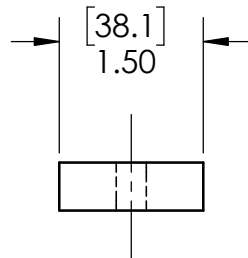
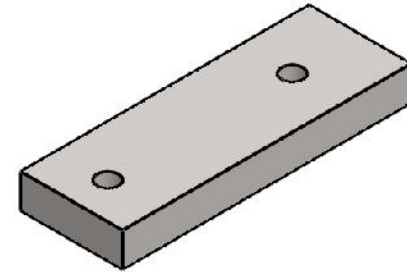
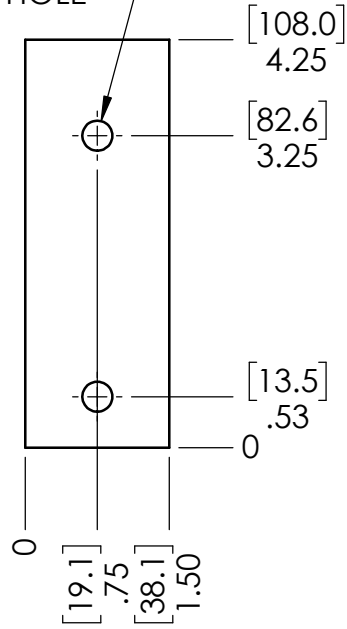

FROM .5X1.5 BAR

**DRAWING NOT  
FOR PRODUCTION USE**

<b>A4</b>	THIRD ANGLE PROJECTION	<b>UNLESS OTHERWISE SPECIFIED:</b>	NAME	DATE	
			DESIGN/ENGR	C. O'BRIEN	2/2020
DIMENSIONS: INCHES (MILLIMETERS)		MATERIAL	DRAWN	9/2020	
		<b>ASTM A36</b>	CHECKED	R. JONES	9/2020
			REV A	R. JONES	12/2021
			COMMENTS:		
			REV A: NO CHANGES		
		DO NOT SCALE DRAWING			

Insurance Institute for Highway Safety  
988 Dairy Rd, Ruckersville, VA 22968 (434) 985-4600

**BARRIER STANCHION  
BOTTOM PLATE**

SCALE: 1:2 WEIGHT: 0.4 KG SHEET 19 of 66

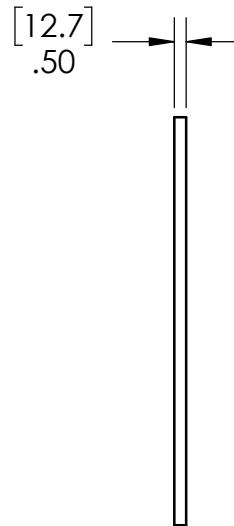
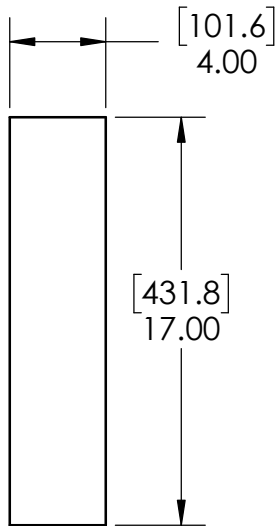
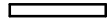

FROM .5X4 BAR

**DRAWING NOT  
FOR PRODUCTION USE**

<b>A4</b>	THIRD ANGLE PROJECTION 	UNLESS OTHERWISE SPECIFIED:	NAME	DATE
		MATERIAL	DESIGN/ENGR	
DIMENSIONS: INCHES (MILLIMETERS)		<b>ASTM A36</b>	C. O'BRIEN	2/2020
			DRAWN	W. SPIVEY
			CHECKED	R. JONES
			REV <b>A</b>	R. JONES
		COMMENTS:	12/2021	
		REV <b>A</b> : NO CHANGES		
		DO NOT SCALE DRAWING		

Insurance Institute for Highway Safety  
988 Dairy Rd, Ruckersville, VA 22968 (434) 985-4600

**BARRIER STANCHION  
FILLER PLATE**

SCALE: 1:8 | WEIGHT: 4.3 KG | SHEET 20 of 66

ITEM NO.	PART NUMBER	PAGE NUMBER	QTY.
1	Z CHANNEL	5	1
2	BARRIER STANCHION	15	1
3	UPPER FLANGE REINFORCEMENT	26	2
4	LOWER BARRIER STANCHION GUSSET	25	2
5	LOWER AXLE HOLE REINFORCEMENT	22	2
86	HBOLT 0.5000-13x2.5x1.25-N		4
87	HBOLT 0.5000-13x3.5x1.25-N		6
88	HBOLT 0.5000-13x1.5x1.25-N		2

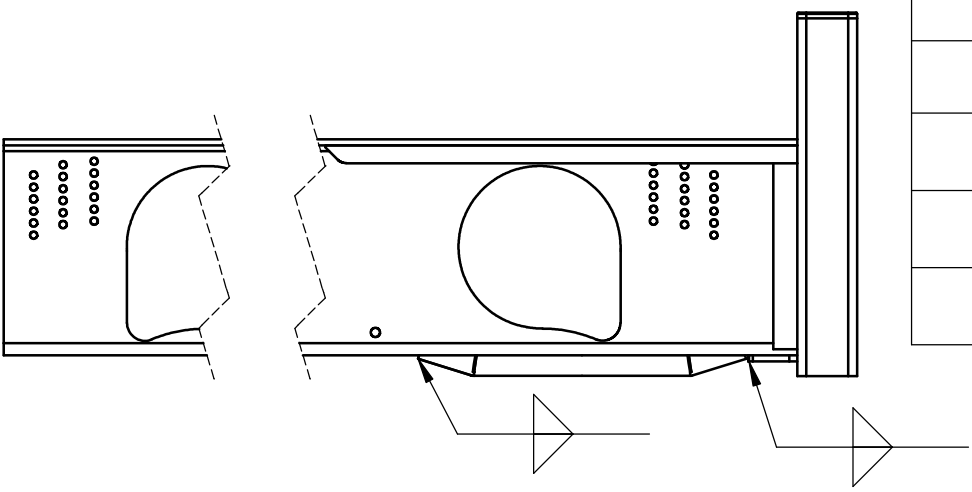

ALIGN HOLES CONCENTRIC

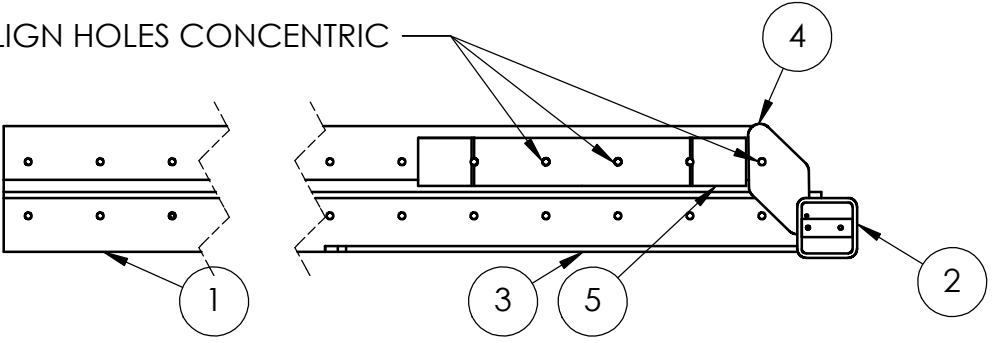

LEFT SIDE SHOWN, RIGHT SIMILAR

**DRAWING NOT FOR PRODUCTION USE**

A4	THIRD ANGLE PROJECTION	UNLESS OTHERWISE SPECIFIED:	NAME	DATE
		MATERIAL	DESIGN/ENGR	C. O'BRIEN 2/2020
DIMENSIONS: INCHES (MILLIMETERS)		N/A	DRAWN	W. SPIVEY 9/2020
			CHECKED	R. JONES 9/2020
			REV A	R. JONES 12/2021
			COMMENTS:	
			REV A: ADD WELDS	
		DO NOT SCALE DRAWING		

Insurance Institute for Highway Safety  
988 Dairy Rd, Ruckersville, VA 22968 (434) 985-4600

**CHASSIS REINFORCEMENT PLACEMENT**

SCALE: 1:16 | WEIGHT: N/A | SHEET 21 of 66

ITEM NO.	PART NUMBER	PAGE NUMBER	QTY.
1	LOWER AXLE HOLE REINFORCEMENT CHANNEL	23	1
2	RIB	24	2

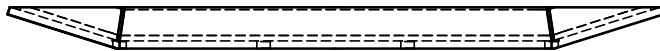
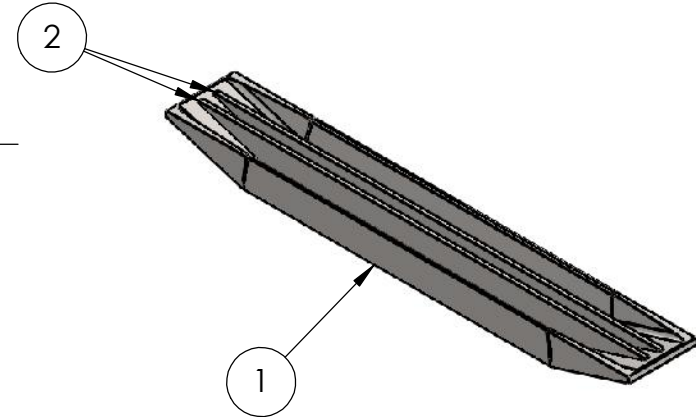
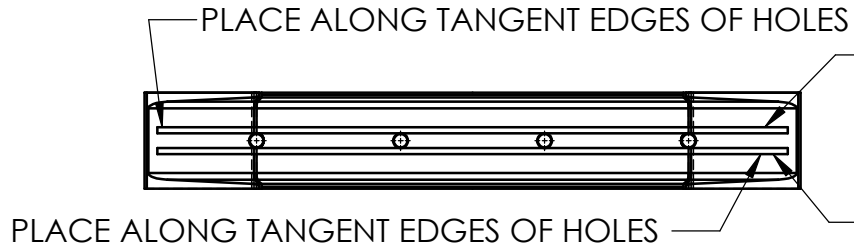

**DRAWING NOT FOR PRODUCTION USE**

<b>A4</b>	THIRD ANGLE PROJECTION	<b>UNLESS OTHERWISE SPECIFIED:</b>	NAME	DATE
			DESIGN/ENGR C. O'BRIEN	2/2020
DIMENSIONS: INCHES (MILLIMETERS)		MATERIAL	DRAWN	9/2020
		N/A	CHECKED	9/2020
			REV A	12/2021
			COMMENTS:	
			REV A: ADD WELDS	
		DO NOT SCALE DRAWING		

Insurance Institute for Highway Safety  
988 Dairy Rd, Ruckersville, VA 22968 (434) 985-4600

**LOWER AXLE HOLE REINFORCEMENT ASSEMBLY**

SCALE: 1:8 | WEIGHT: 9 KG | SHEET 22 of 66

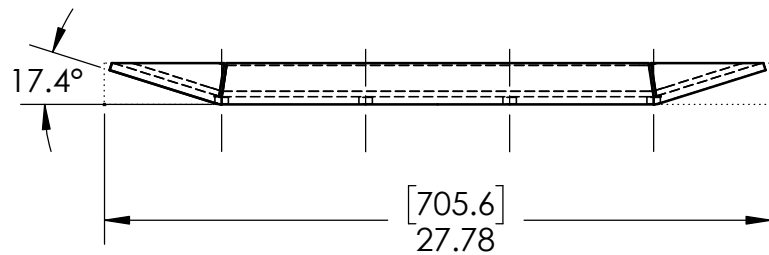
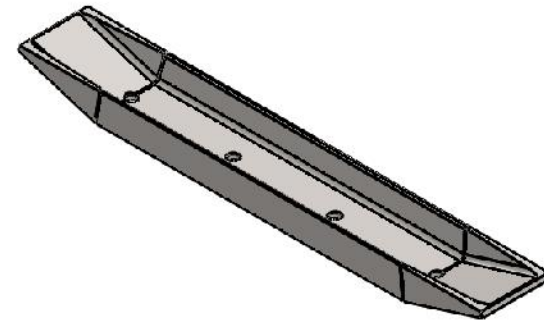
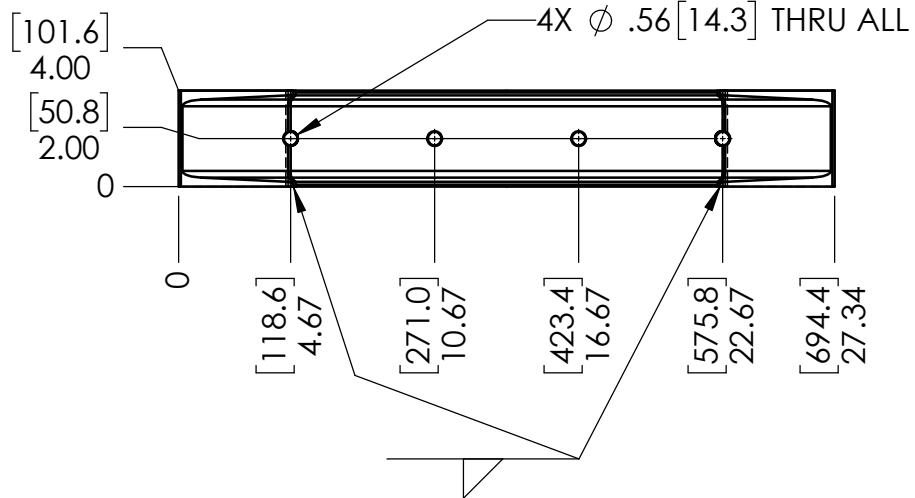

FROM C4X7.25 CHANNEL

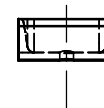

**DRAWING NOT  
FOR PRODUCTION USE**

<b>A4</b>	THIRD ANGLE PROJECTION	UNLESS OTHERWISE SPECIFIED:	NAME	DATE
		MATERIAL	DESIGN/ENGR	
DIMENSIONS: INCHES (MILLIMETERS)		<b>ASTM A36</b>	C. O'BRIEN	2/2020
			DRAWN	W. SPIVEY
			CHECKED	R. JONES
			REV A	R. JONES
			COMMENTS:	12/2021
			REV A: NO CHANGES	
		DO NOT SCALE DRAWING		

Insurance Institute for Highway Safety  
 988 Dairy Rd, Ruckersville, VA 22968 (434) 985-4600

**LOWER AXLE HOLE  
REINFORCEMENT CHANNEL**

SCALE: 1:8 | WEIGHT: 7 KG | SHEET 23 of 66

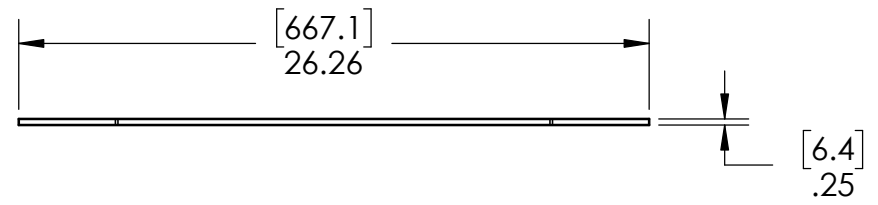
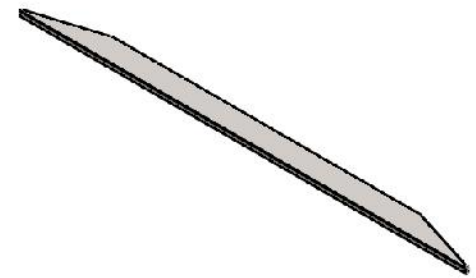
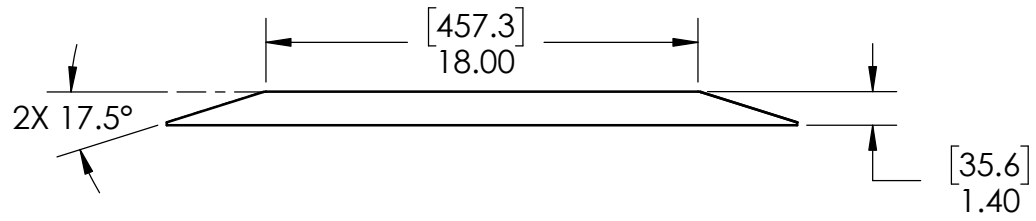

**DRAWING NOT  
FOR PRODUCTION USE**

A4	THIRD ANGLE PROJECTION	UNLESS OTHERWISE SPECIFIED:	NAME	DATE	
		MATERIAL	DESIGN/ENGR		
DIMENSIONS: INCHES (MILLIMETERS)		ASTM A36	C. O'BRIEN	2/2020	
			DRAWN	W. SPIVEY	9/2020
			CHECKED	R. JONES	9/2020
			REV A	R. JONES	12/2021
			COMMENTS:		
			REV A: NO CHANGES		
		DO NOT SCALE DRAWING			

Insurance Institute for Highway Safety  
988 Dairy Rd, Ruckersville, VA 22968 (434) 985-4600

**LOWER AXLE HOLE  
REINFORCEMENT RIB**

SCALE: 1:8 | WEIGHT: 1 KG | SHEET 24 of 66



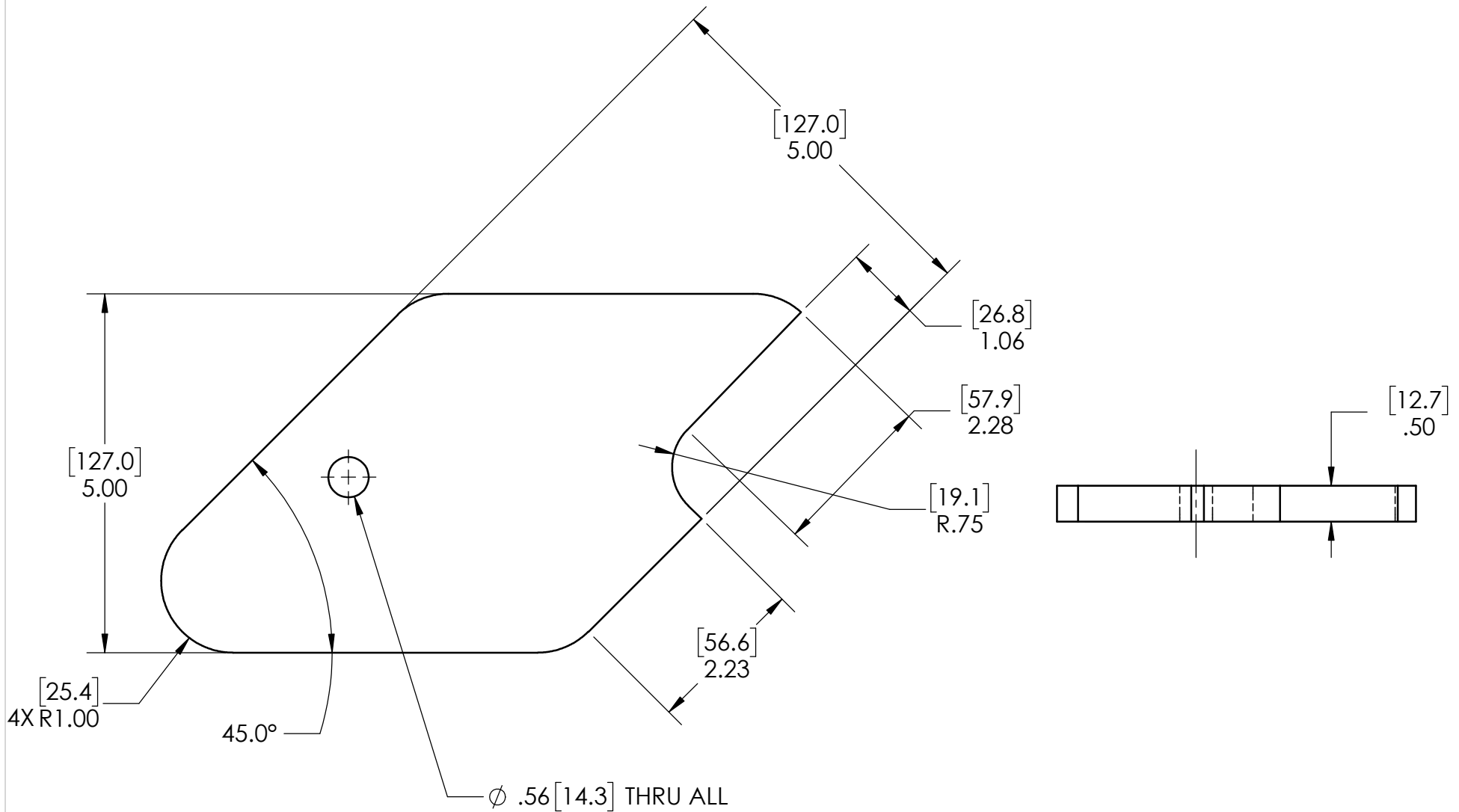

**DRAWING NOT  
FOR PRODUCTION USE**

A4	THIRD ANGLE PROJECTION	UNLESS OTHERWISE SPECIFIED:	NAME	DATE
		MATERIAL	DESIGN/ENGR	C. O'BRIEN 2/2020
DIMENSIONS: INCHES (MILLIMETERS)		ASTM A36	DRAWN	W. SPIVEY 9/2020
			CHECKED	R. JONES 9/2020
			REV A	R. JONES 12/2021
			COMMENTS:	
		DO NOT SCALE DRAWING	REV A: NO CHANGES	

Insurance Institute for Highway Safety  
988 Dairy Rd, Ruckersville, VA 22968 (434) 985-4600

## STANCHION GUSSET

SCALE: 1:2    WEIGHT: 1.9 KG    SHEET 25 of 66

5

4

3

2

1

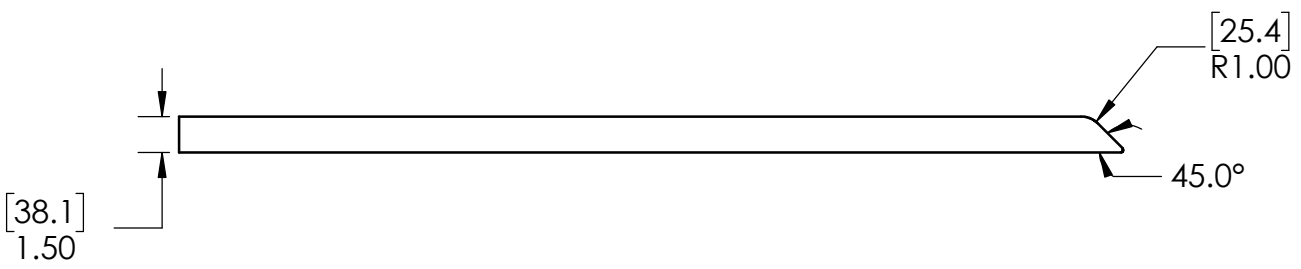
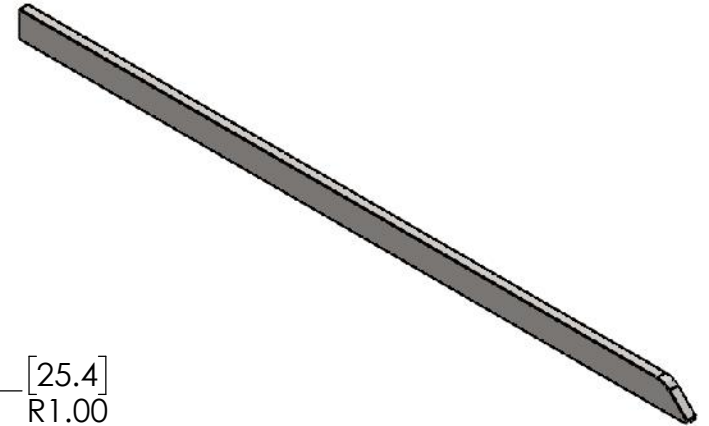
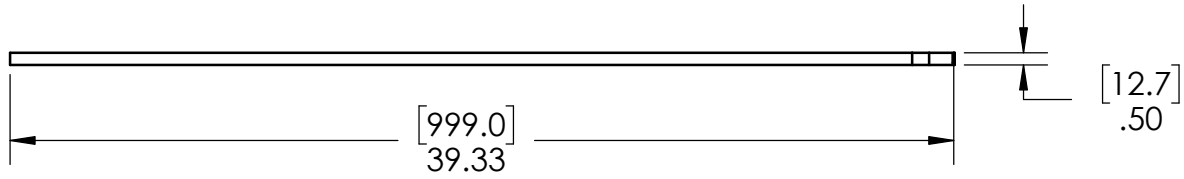

**DRAWING NOT FOR PRODUCTION USE**

<b>A4</b>	THIRD ANGLE PROJECTION	<b>UNLESS OTHERWISE SPECIFIED:</b>	NAME	DATE
			DESIGN/ENGR C. O'BRIEN	2/2020
DIMENSIONS: INCHES (MILLIMETERS)		MATERIAL	DRAWN	9/2020
		<b>ASTM A36</b>	CHECKED	R. JONES
			REV A	R. JONES
			COMMENTS:	12/2021
		DO NOT SCALE DRAWING	REV A: NO CHANGES	

Insurance Institute for Highway Safety		
988 Dairy Rd, Ruckersville, VA 22968 (434) 985-4600		
<b>UPPER FLANGE REINFORCEMENT</b>		
SCALE: 1:8	WEIGHT: 3.7 KG	SHEET 26 of 66

ITEM NO.	PART NUMBER	PAGE NUMBER	QTY.
1	Z CHANNEL	5	2
2	LOWER CONTROL ARM FRAME MOUNT, LEFT AND RIGHT	28	4
42	HBOLT 0.5000-13x2.5x1.25-N		4
	HBOLT 0.5000-13x3.5x1.25-N		6
	HBOLT 0.5000-13x4.5x1.25-N		2

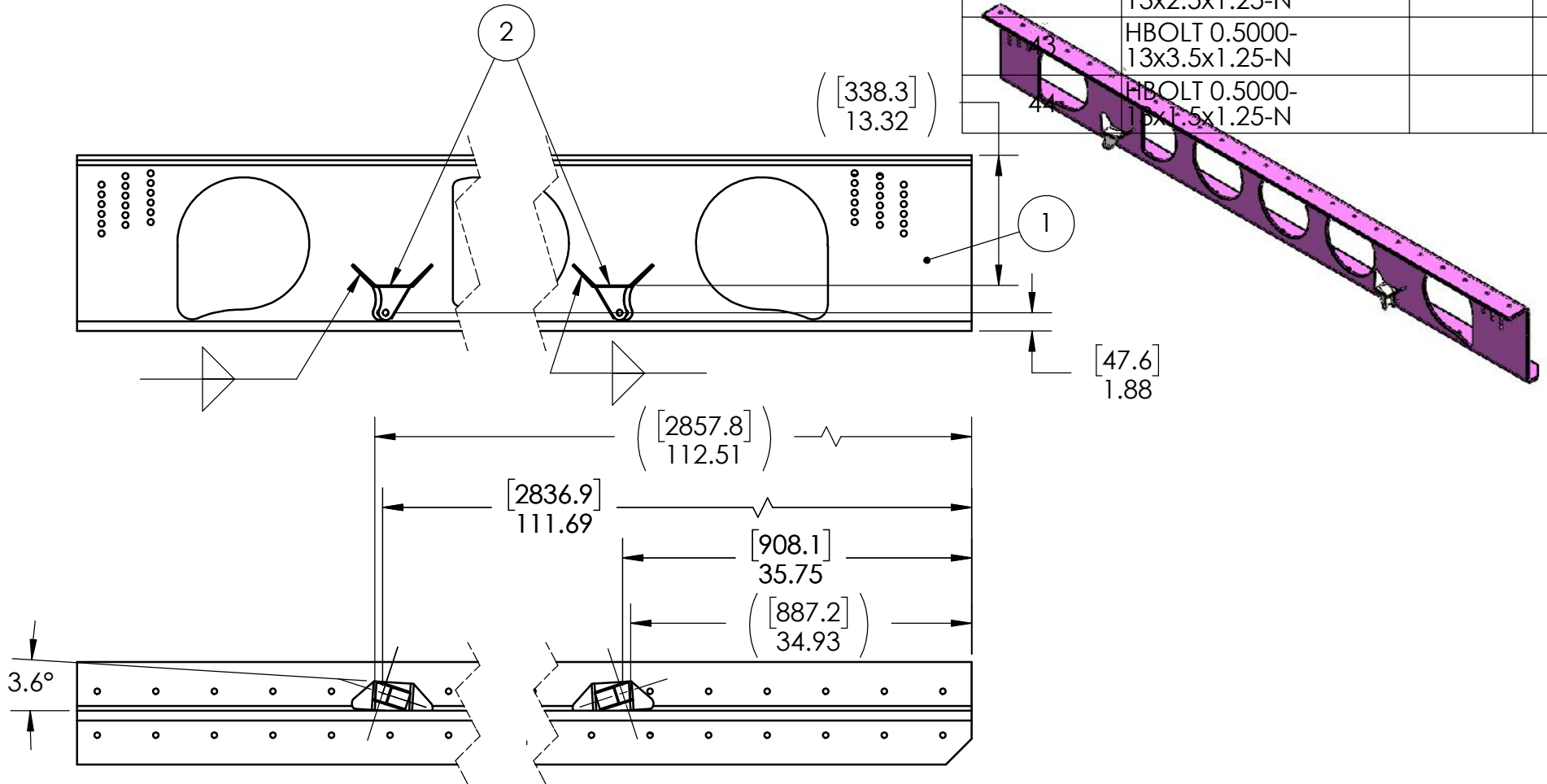

RIGHT OUTSIDE CHANNEL SHOWN,  
LEFT SIMILAR

**DRAWING NOT  
FOR PRODUCTION USE**

<b>A4</b>	THIRD ANGLE PROJECTION	<b>UNLESS OTHERWISE SPECIFIED:</b>	NAME	DATE
		MATERIAL	DESIGN/ENGR	C. O'BRIEN 2/2020
	DIMENSIONS: INCHES (MILLIMETERS)	N/A	DRAWN	W. SPIVEY 9/2020
			CHECKED	R. JONES 9/2020
			REV A	R. JONES 12/2021
			COMMENTS:	
			REV A: UPDATE MODEL AND DIMS ADD WELDS	
		DO NOT SCALE DRAWING		

Insurance Institute for Highway Safety  
988 Dairy Rd, Ruckersville, VA 22968 (434) 985-4600

**LOWER CONTROL ARM  
MOUNT PLACEMENT**

SCALE: 1:16    WEIGHT: N/A    SHEET 27 of 66

ITEM NO.	PART NUMBER	PAGE NUMBER	QTY.
1	LOWER CONTROL ARM PLATE	30	1
2	LOWER CONTROL ARM FRAME TAB	29	1

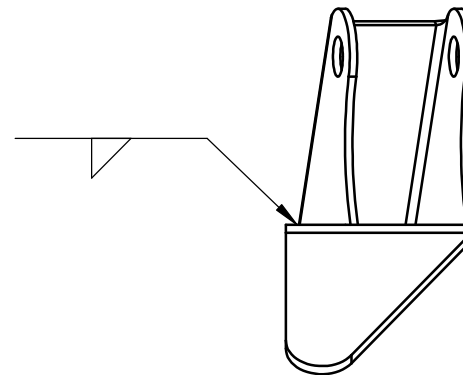
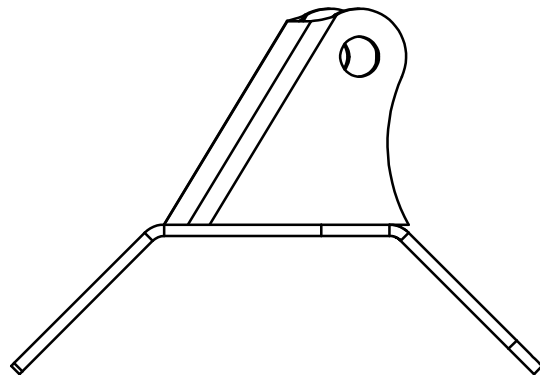
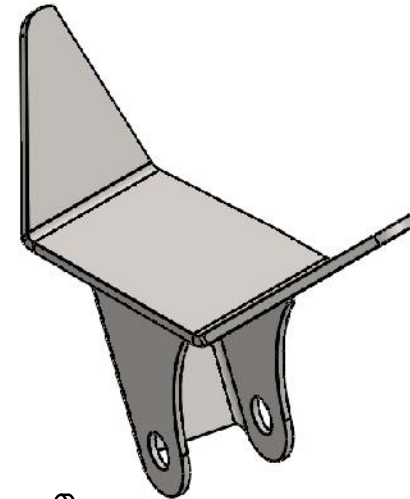
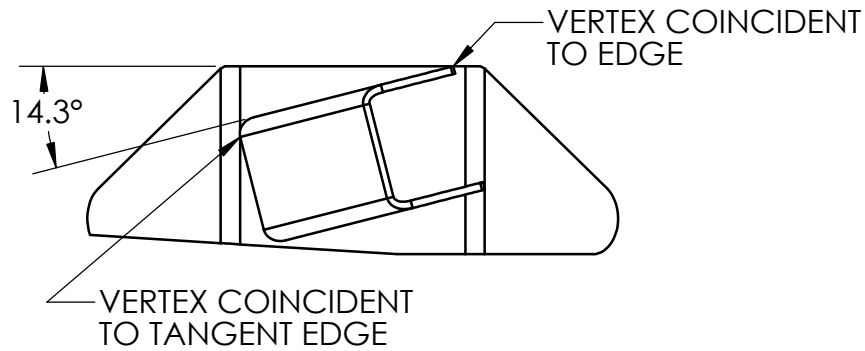

RIGHT REAR, LEFT FRONT SHOWN,  
LEFT REAR, RIGHT FRONT OPPOSITE

SEE VENDOR LIST PAGE 62 FOR SUPPLIERS. PART DETAILED FOR PRODUCTION.

**DRAWING NOT FOR PRODUCTION USE**

A4	THIRD ANGLE PROJECTION	UNLESS OTHERWISE SPECIFIED:		NAME	DATE
		MATERIAL	N/A	DESIGN/ENGR	C. O'BRIEN 2/2020
DIMENSIONS: INCHES (MILLIMETERS)				DRAWN	W. SPIVEY 9/2020
				CHECKED	R. JONES 9/2020
				REV A	R. JONES 12/2021
				COMMENTS:	
				REV A: UPDATE MODEL AND DIMS ADD WELDS	
		DO NOT SCALE DRAWING			

Insurance Institute for Highway Safety  
988 Dairy Rd, Ruckersville, VA 22968 (434) 985-4600

## LOWER CONTROL ARM FRAME MOUNT ASSEMBLY

SCALE: 1:3    WEIGHT: 0.8 KG    SHEET 28 of 66

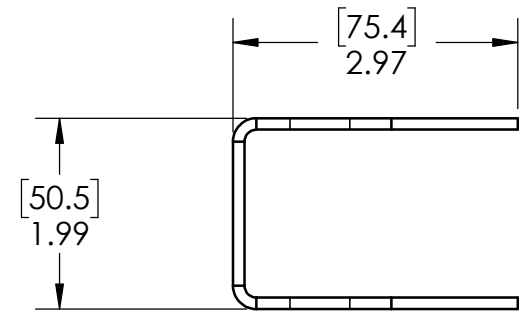
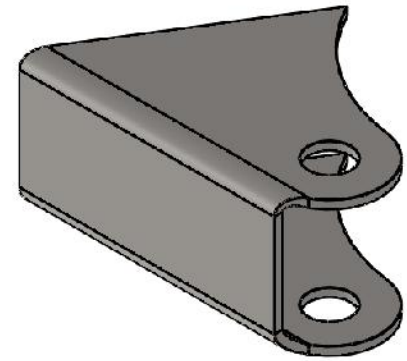
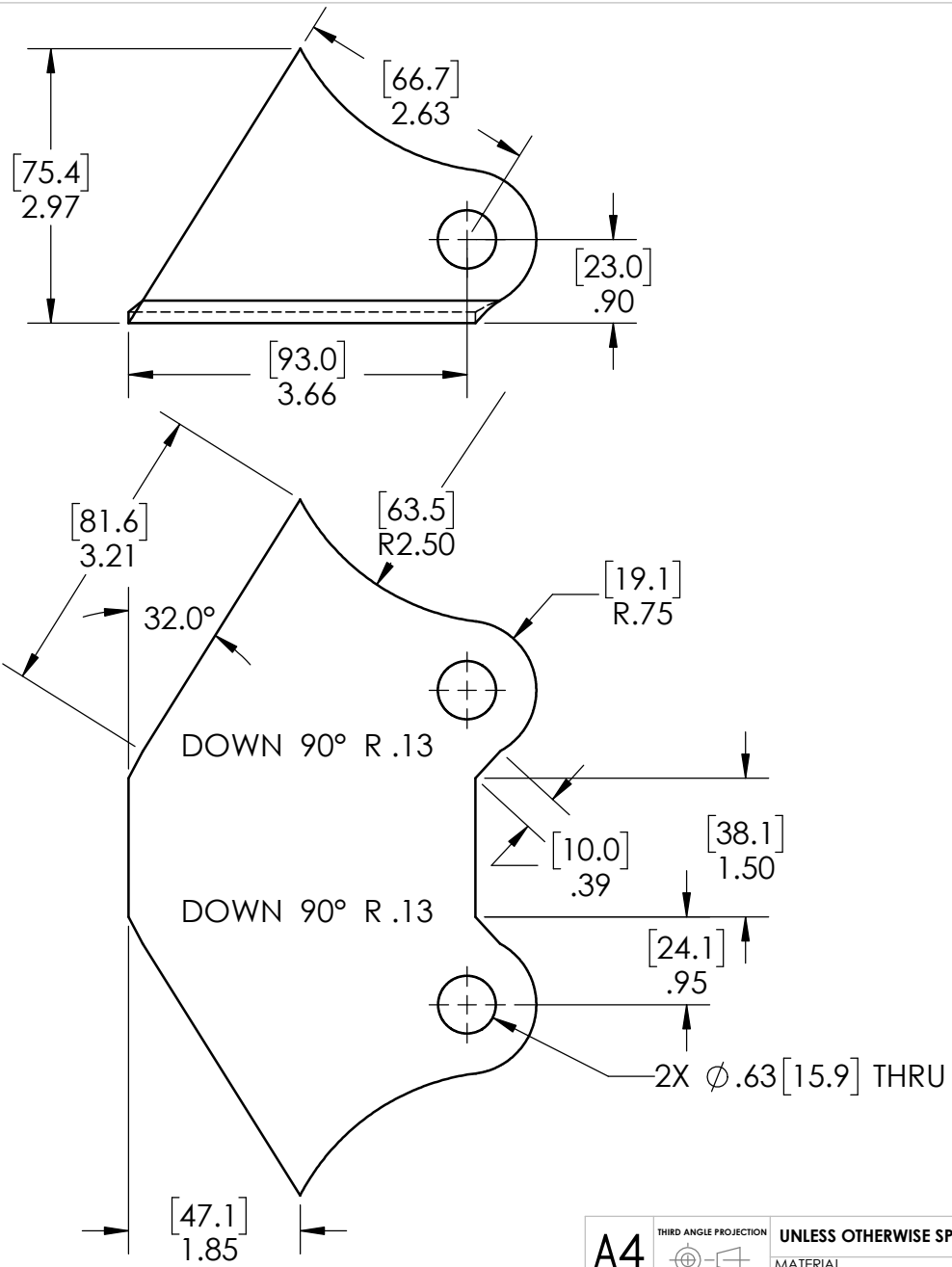

**DRAWING NOT  
FOR PRODUCTION USE**

<b>A4</b>	THIRD ANGLE PROJECTION	UNLESS OTHERWISE SPECIFIED:	NAME	DATE
		MATERIAL	DESIGN/ENGR	
DIMENSIONS: INCHES (MILLIMETERS)		<b>AISI C1018</b>	C. O'BRIEN	2/2020
			DRAWN	W. SPIVEY
			CHECKED	R. JONES
			REV A	R. JONES
			COMMENTS:	12/2021
			REV A: NO CHANGES	
		DO NOT SCALE DRAWING		

Insurance Institute for Highway Safety  
988 Dairy Rd, Ruckersville, VA 22968 (434) 985-4600

**LOWER CONTROL  
ARM FRAME TAB**

SCALE: 1:2    WEIGHT: 0.3 KG    SHEET 29 of 66

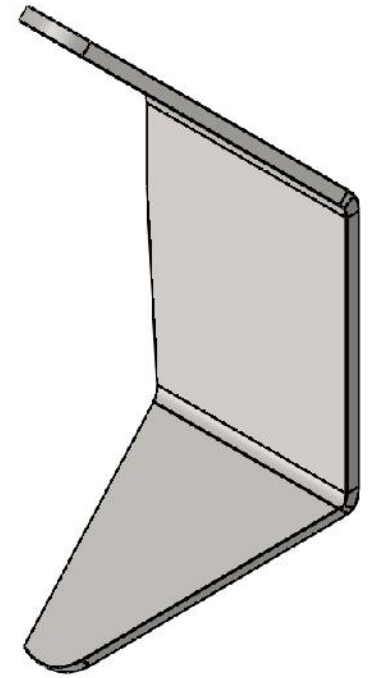
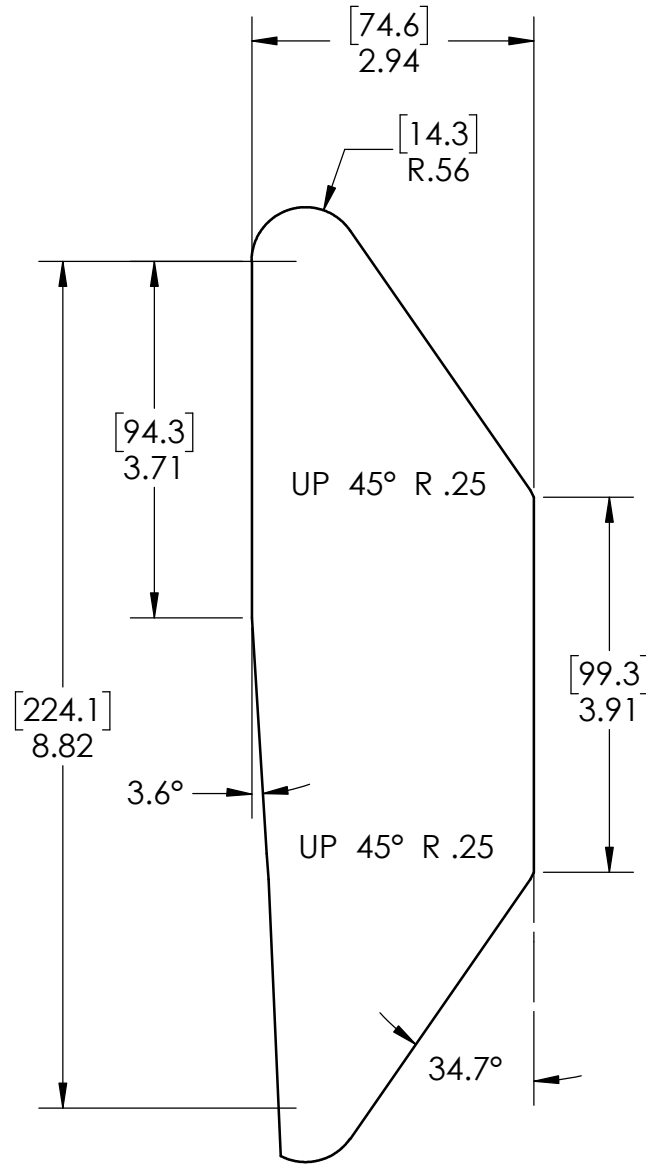
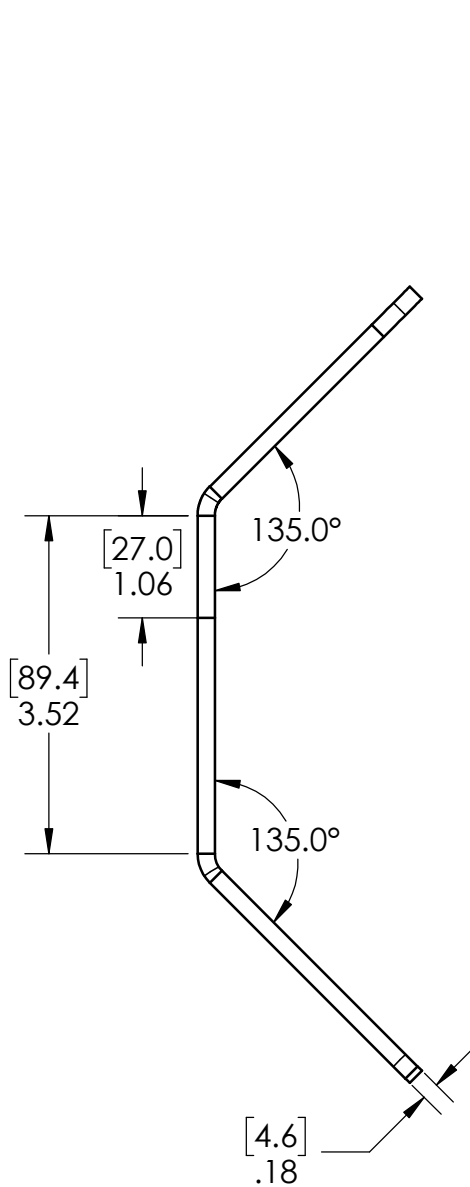

**DRAWING NOT  
FOR PRODUCTION USE**

<b>A4</b>	THIRD ANGLE PROJECTION	<b>UNLESS OTHERWISE SPECIFIED:</b>	NAME	DATE	
			DESIGN/ENGR	C. O'BRIEN	2/2020
DIMENSIONS: INCHES (MILLIMETERS)		MATERIAL	DRAWN	9/2020	
		<b>AISI C1018</b>	CHECKED	R. JONES	9/2020
			REV A	R. JONES	12/2021
			COMMENTS:		
			REV A: NO CHANGES		
		DO NOT SCALE DRAWING			

Insurance Institute for Highway Safety  
988 Dairy Rd, Ruckersville, VA 22968 (434) 985-4600

**LOWER CONTROL  
ARM FRAME PLATE**

SCALE: 1:2 | WEIGHT: 0.5 KG | SHEET 30 of 66

5

4

3

2

1

ITEM NO.	PART NUMBER	PAGE NUMBER	QTY.
1	Z CHANNEL	6	1
2	UPPER CONTROL FRAME END TAB	32	4

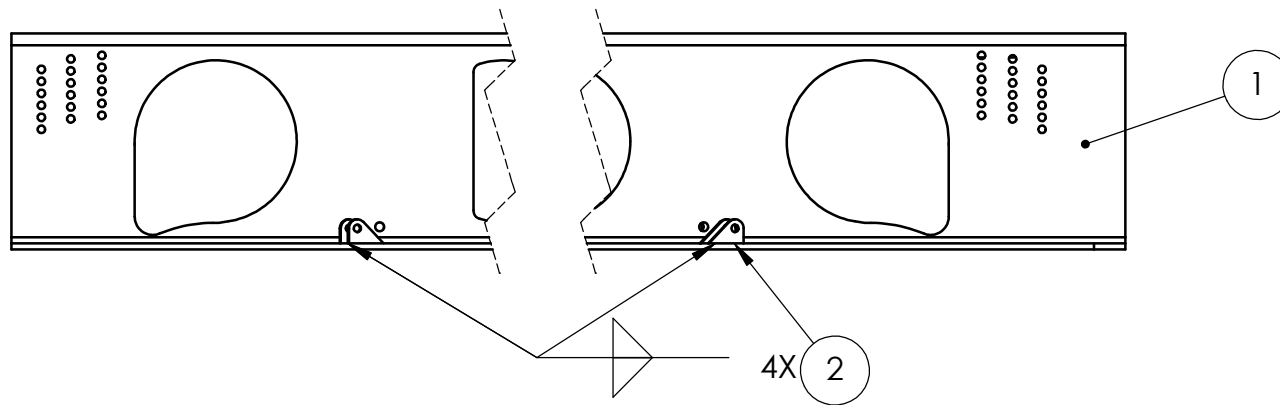
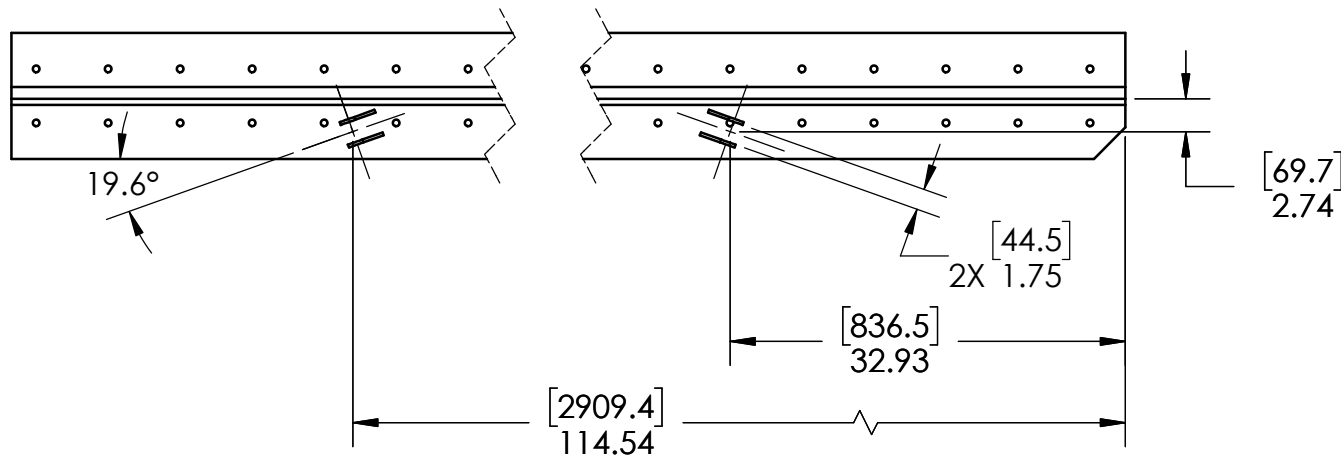

LEFT INSIDE CHANNEL SHOWN,  
RIGHT SIDE SIMILAR

**DRAWING NOT  
FOR PRODUCTION USE**

A4		THIRD ANGLE PROJECTION	UNLESS OTHERWISE SPECIFIED:		NAME	DATE
DIMENSIONS: INCHES (MILLIMETERS)			MATERIAL	N/A	DESIGN/ENGR	C. O'BRIEN 2/2020
					DRAWN	W. SPIVEY 9/2020
					CHECKED	R. JONES 9/2020
					REV A	R. JONES 12/2021
					COMMENTS:	
				REV A: UPDATE MODEL ADD DIMS ADD WELDS		
			DO NOT SCALE DRAWING			

Insurance Institute for Highway Safety  
988 Dairy Rd, Ruckersville, VA 22968 (434) 985-4600

**UPPER CONTROL ARM  
PLACEMENT**

SCALE: 1:16 | WEIGHT: N/A | SHEET 31 of 66

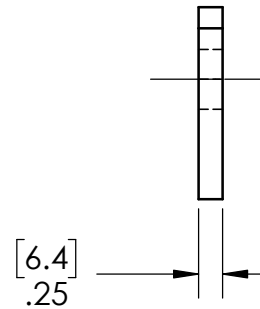
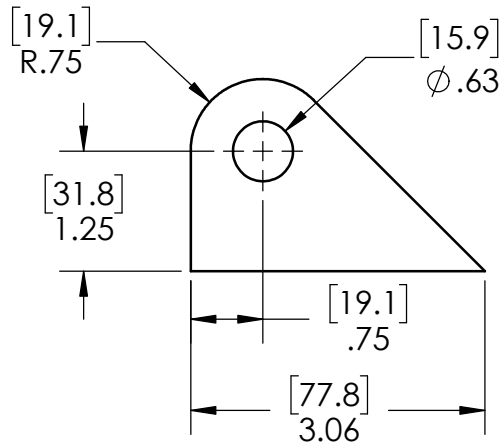
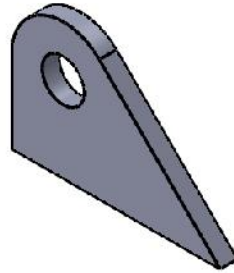
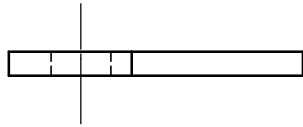

**DRAWING NOT  
FOR PRODUCTION USE**

<b>A4</b>	THIRD ANGLE PROJECTION	<b>UNLESS OTHERWISE SPECIFIED:</b>	NAME	DATE
		MATERIAL	DESIGN/ENGR	C. O'BRIEN 2/2020
DIMENSIONS: INCHES (MILLIMETERS)		<b>AINSI C1018</b>	DRAWN	W. SPIVEY 9/2020
			CHECKED	R. JONES 9/2020
			REV A	R. JONES 12/2021
			COMMENTS:	
		DO NOT SCALE DRAWING	REV A: REMOVE MOUNT ADD TAB	

Insurance Institute for Highway Safety  
988 Dairy Rd, Ruckersville, VA 22968 (434) 985-4600

**UPPER CONTROL  
FRAME END TAB**

SCALE: 1:2 | WEIGHT: 0.4 KG | SHEET 32 of 66



ITEM NO.	PART NUMBER	PAGE #	QTY.
1	3500# 4" DROP 66" HUB-HUB AXLE ASSEMBLY WITH DISC BRAKES	66	1
2	CONTROL ARM TAB LOW INNER	38	2
3	CONTROL ARM TAB SQUARE SHORT	38	2
4	AXLE TRUSS	37	1
5	BENT DROP SPINDLE GUSSET	39	2
6	DROP SPINDLE GUSSET	39	2
7	LOW SHOCK MT SW AXLE	40	2
8	UPPER CONTROL ARM TAB	35	4

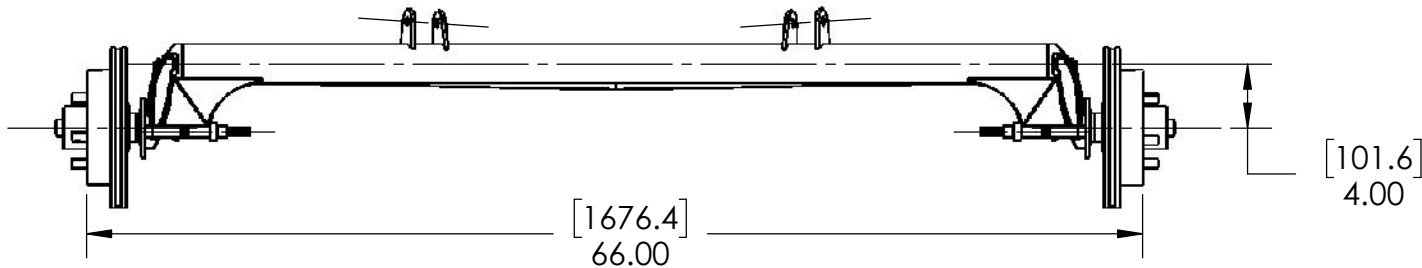
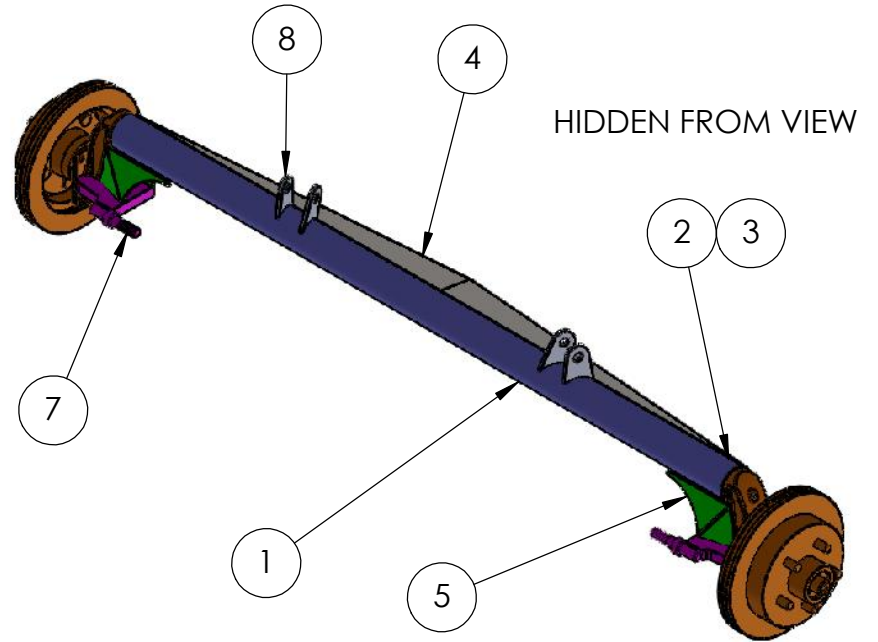

**DRAWING NOT FOR PRODUCTION USE**

A4	THIRD ANGLE PROJECTION	UNLESS OTHERWISE SPECIFIED:	NAME	DATE
		MATERIAL	DESIGN/ENGR	C. O'BRIEN 2/2020
DIMENSIONS: INCHES (MILLIMETERS)		N/A	DRAWN	W. SPIVEY 9/2020
			CHECKED	R. JONES 9/2020
			REV A	R. JONES 12/2021
			COMMENTS:	
			REV A:	
		DO NOT SCALE DRAWING		

Insurance Institute for Highway Safety  
988 Dairy Rd, Ruckersville, VA 22968 (434) 985-4600

**DETAILED AXLE ASSEMBLY**

SCALE: 1:12 | WEIGHT: 44 KG | SHEET 33 of 66

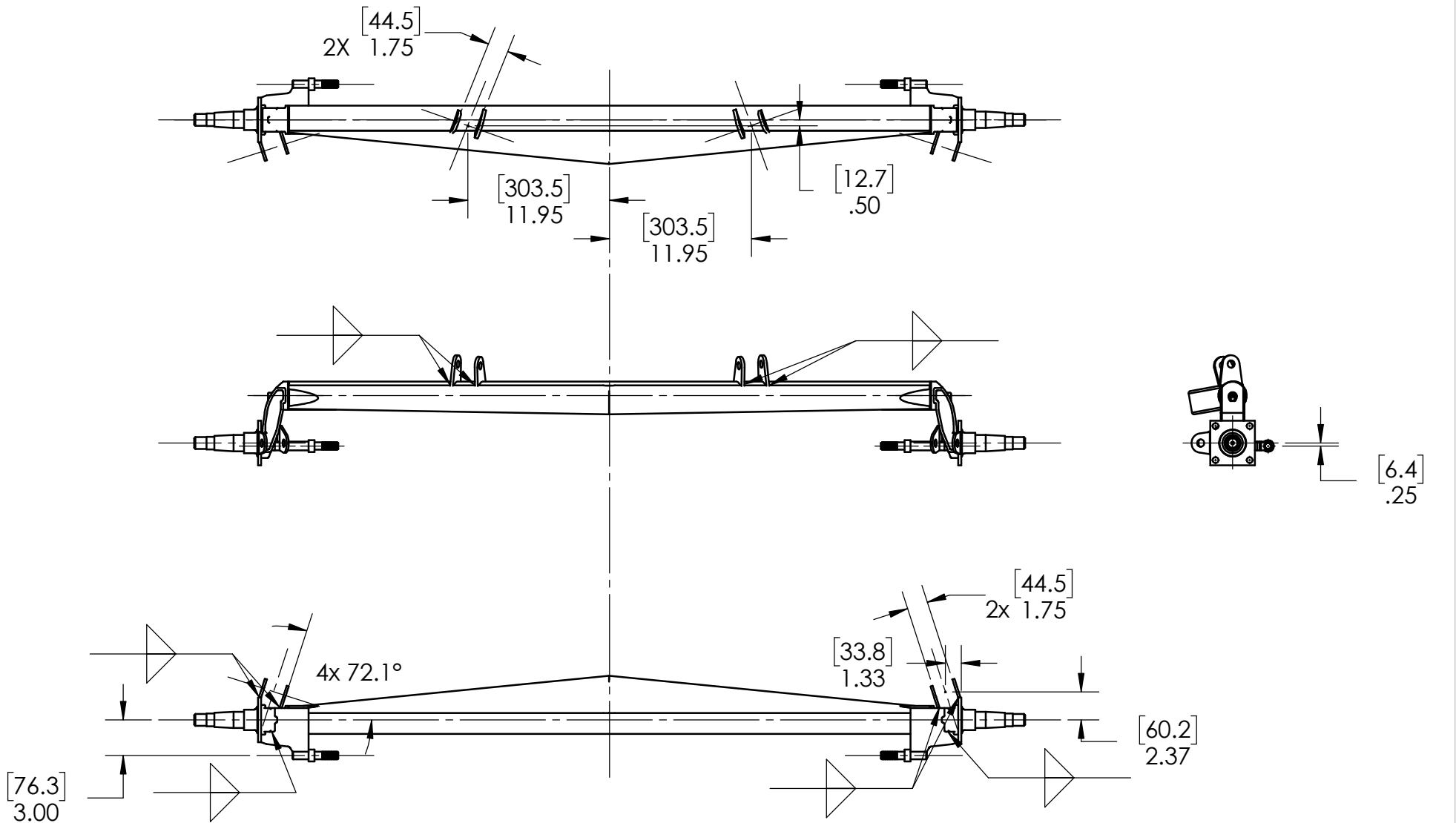

**DRAWING NOT  
FOR PRODUCTION USE**

A4	THIRD ANGLE PROJECTION	UNLESS OTHERWISE SPECIFIED:	NAME	DATE
		MATERIAL	DESIGN/ENGR	C. O'BRIEN 2/2020
DIMENSIONS: INCHES (MILLIMETERS)		N/A	DRAWN	W. SPIVEY 9/2020
			CHECKED	R. JONES 9/2020
			REV A	R. JONES 12/2021
			COMMENTS:	
		DO NOT SCALE DRAWING	REV A: UPDATE CONTROL ARM TABS, LOWER SHOCK MOUNT	

Insurance Institute for Highway Safety		
988 Dairy Rd, Ruckersville, VA 22968 (434) 985-4600		
<b>CONTROL ARM TAB AND LOWER SHOCK MOUNT PLACEMENT</b>		
SCALE: 1:12	WEIGHT: N/A	SHEET 34 of 66

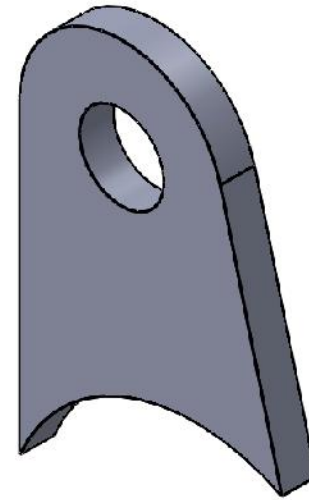
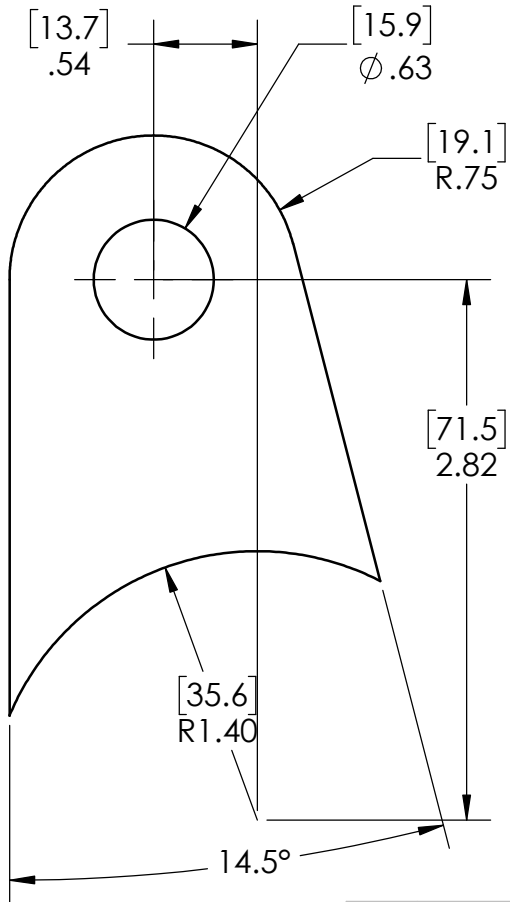
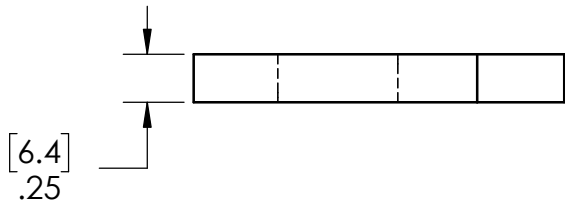

**DRAWING NOT  
FOR PRODUCTION USE**

<b>A4</b>	THIRD ANGLE PROJECTION	<b>UNLESS OTHERWISE SPECIFIED:</b>	NAME	DATE
		MATERIAL	DESIGN/ENGR	
DIMENSIONS: INCHES (MILLIMETERS)		<b>AISI C1018</b>	C. O'BRIEN	2/2020
			DRAWN	W. SPIVEY
			CHECKED	R. JONES
			REV <b>A</b>	R. JONES
			COMMENTS:	12/2021
		DO NOT SCALE DRAWING	REV <b>A</b> : REVISED TAB	

Insurance Institute for Highway Safety  
988 Dairy Rd, Ruckersville, VA 22968 (434) 985-4600

**UPPER CONTROL ARM  
TAB**

SCALE: 1:2 | WEIGHT: 0.08 KG | SHEET 35 of 66

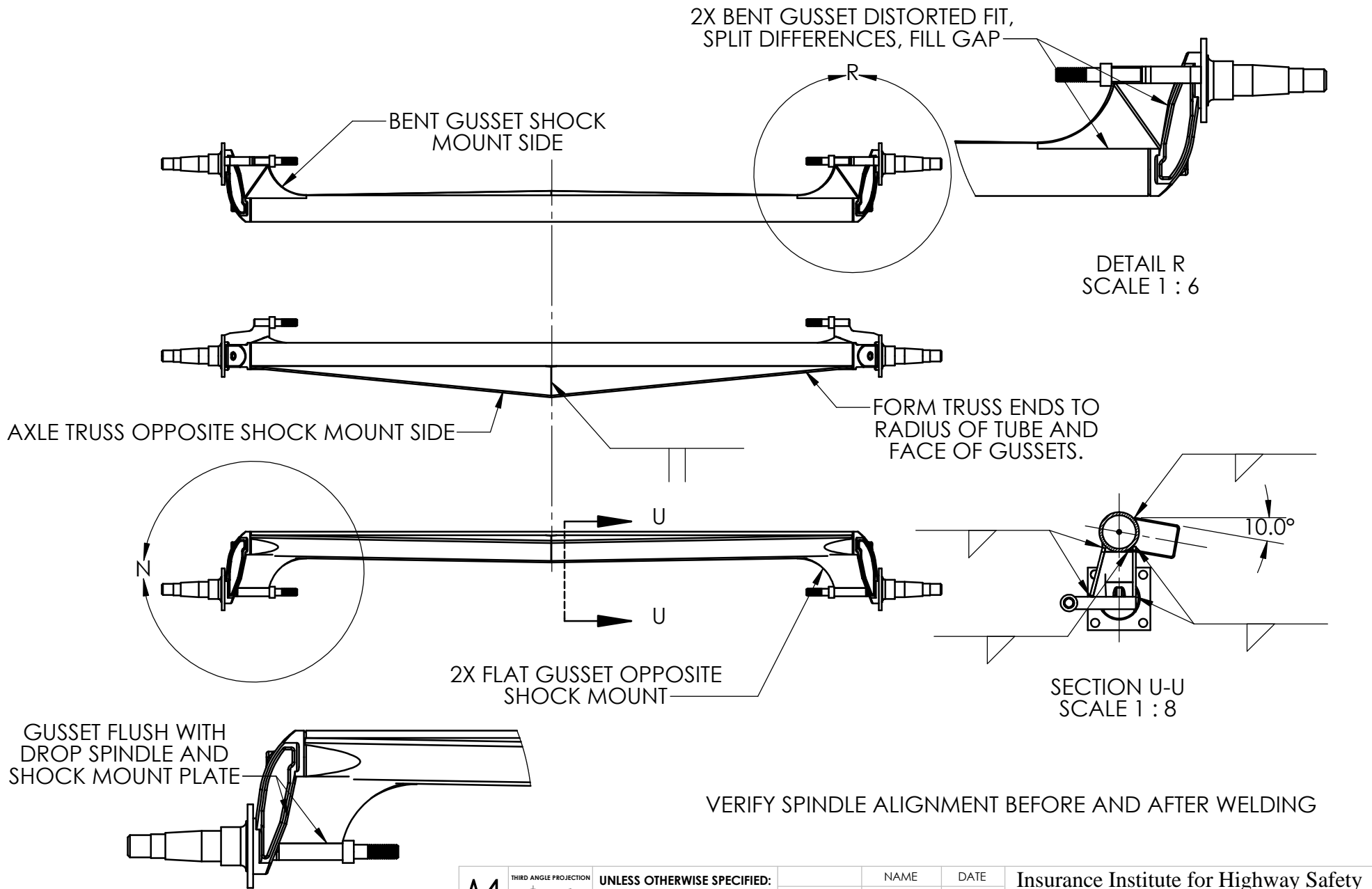

**DRAWING NOT FOR PRODUCTION USE**

A4	THIRD ANGLE PROJECTION	UNLESS OTHERWISE SPECIFIED:	NAME	DATE
		MATERIAL	DESIGN/ENGR	C. O'BRIEN 2/2020
DIMENSIONS: INCHES (MILLIMETERS)		N/A	DRAWN	W. SPIVEY 9/2020
			CHECKED	R. JONES 9/2020
			REV A	R JONES 12/2021
			COMMENTS:	
			REV A: ADD SHEET	
		DO NOT SCALE DRAWING		

Insurance Institute for Highway Safety  
988 Dairy Rd, Ruckersville, VA 22968 (434) 985-4600

# AXLE REINFORCEMENTS

SCALE: 1:12 WEIGHT: SHEET 36 of 66

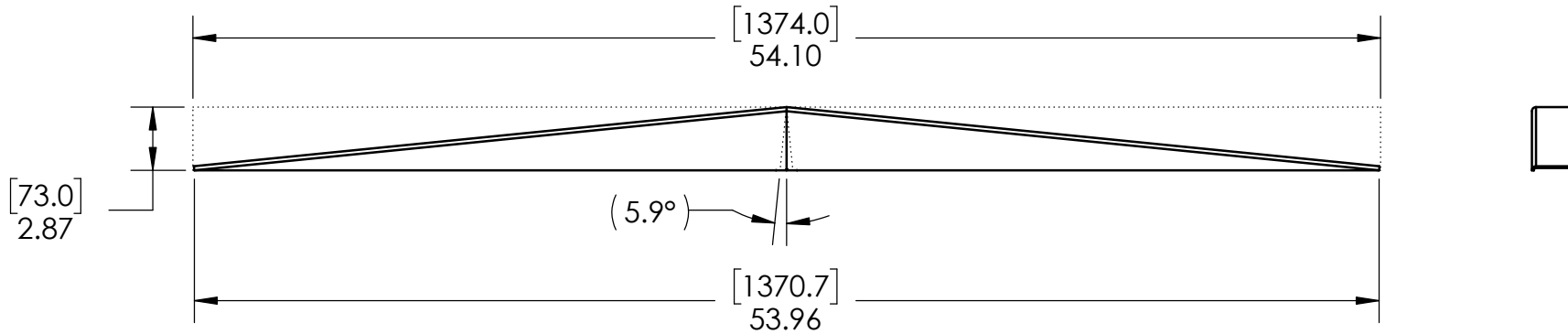
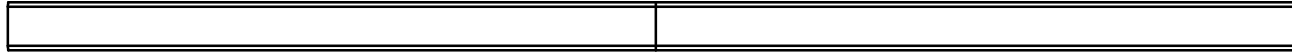

FROM 3X2X.1875 TUBING

**DRAWING NOT  
FOR PRODUCTION USE**

<b>A4</b>	THIRD ANGLE PROJECTION	UNLESS OTHERWISE SPECIFIED:	NAME	DATE	Insurance Institute for Highway Safety 988 Dairy Rd, Ruckersville, VA 22968 (434) 985-4600	
		MATERIAL	DESIGN/ENGR	C. O'BRIEN		2/2020
DIMENSIONS: INCHES (MILLIMETERS)	<b>ASTM A500</b>		DRAWN	W. SPIVEY		9/2020
			CHECKED	R. JONES		9/2020
			REV A	R JONES		12/2021
		COMMENTS: REV A: ADD SHEET				
		DO NOT SCALE DRAWING				

**AXLE TRUSS**

SCALE: 1:2    WEIGHT: 2.7 KG    SHEET 37 of 66

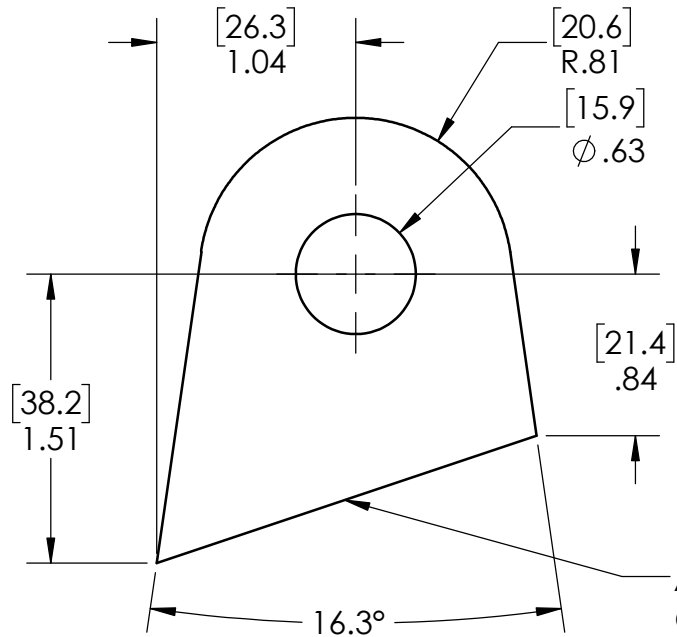

INNER TAB 2 PER AXLE

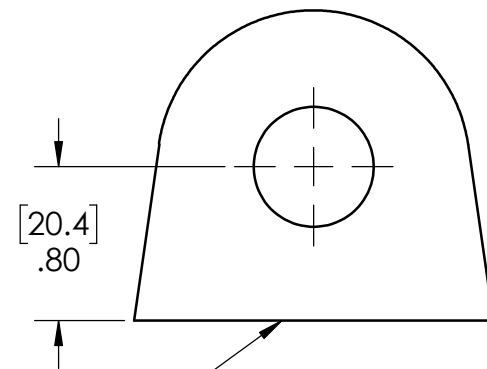

OUTER TAB 2 PER AXLE

ACTUAL EDGE PROFILE DEPENDENT ON PROFILE OF DROP SPINDLE FOR SPECIFIC AXLE MODEL

FROM 3/16[5] FLAT STOCK

**DRAWING NOT FOR PRODUCTION USE**

<b>A4</b>	THIRD ANGLE PROJECTION	<b>UNLESS OTHERWISE SPECIFIED:</b>		NAME	DATE
		MATERIAL	<b>AISI 1018</b>	DESIGN/ENGR	C. O'BRIEN 2/2020
DIMENSIONS: INCHES (MILLIMETERS)				DRAWN	W. SPIVEY 9/2020
				CHECKED	R. JONES 9/2020
				REV A	R JONES 12/2021
				COMMENTS:	
				REV A: ADD SHEET	
				DO NOT SCALE DRAWING	

Insurance Institute for Highway Safety  
988 Dairy Rd, Ruckersville, VA 22968 (434) 985-4600

**LOWER CONT ARM AXLE TABS**

SCALE: 1:1 | WEIGHT: 0.05 KG | SHEET 38 of 66

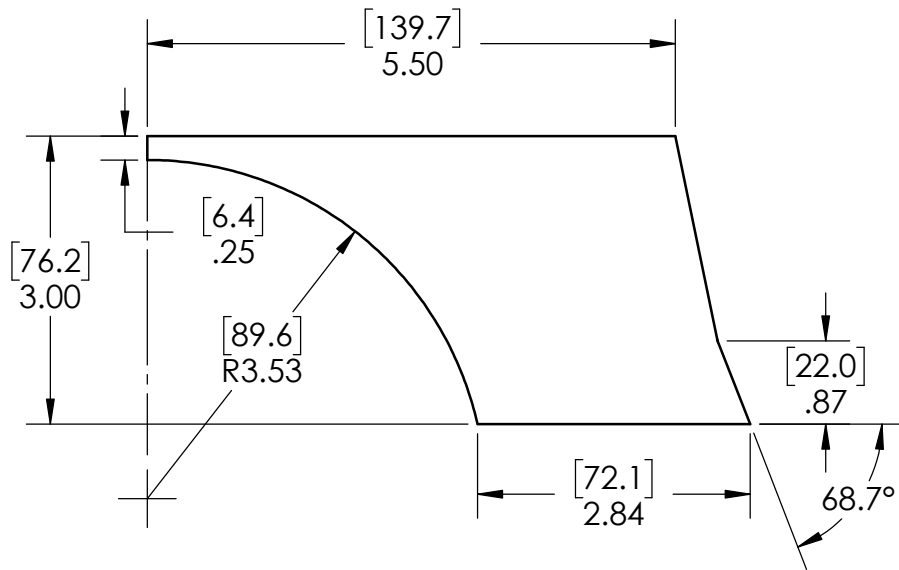

FLAT GUSSET 2 RQD PER AXLE

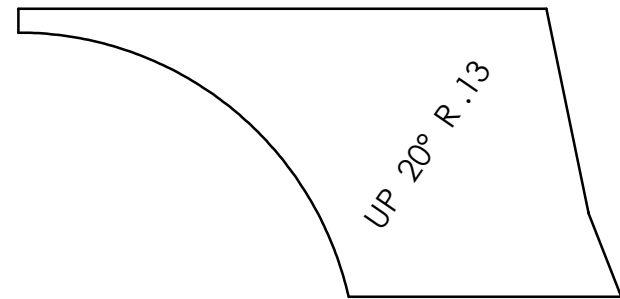

BENT GUSSET, SAME CUT AS FLAT  
ONE SIDE SHOWN  
1 RQD PER AXLE, 1 OPP HAND

FROM 3/16[5] PLATE

**DRAWING NOT  
FOR PRODUCTION USE**

<b>A4</b>	THIRD ANGLE PROJECTION	UNLESS OTHERWISE SPECIFIED:	NAME	DATE
		MATERIAL	DESIGN/ENGR	
DIMENSIONS: INCHES (MILLIMETERS)		AISI 1018	C. O'BRIEN	2/2020
			DRAWN	W. SPIVEY
			CHECKED	R. JONES
			REV A	R JONES
		COMMENTS:	12/2021	
		DO NOT SCALE DRAWING	REV A: ADD SHEET	

Insurance Institute for Highway Safety  
988 Dairy Rd, Ruckersville, VA 22968 (434) 985-4600

**AXLE DROP GUSSETS**

SCALE: 1:2 WEIGHT: 0.25 KG SHEET 39 of 66

ITEM NO.	PART NUMBER	PAGE NO.	QTY.
1	LOWER SHOCK MOUNT PLATE	41	1
2	MOD HEX BOLT 5/8-11X5.5 CUT TO LENGTH		1
3	SHOCK SPACER	42	1
5	HBOLT 0.6250-11x4.5x1.5-N		1

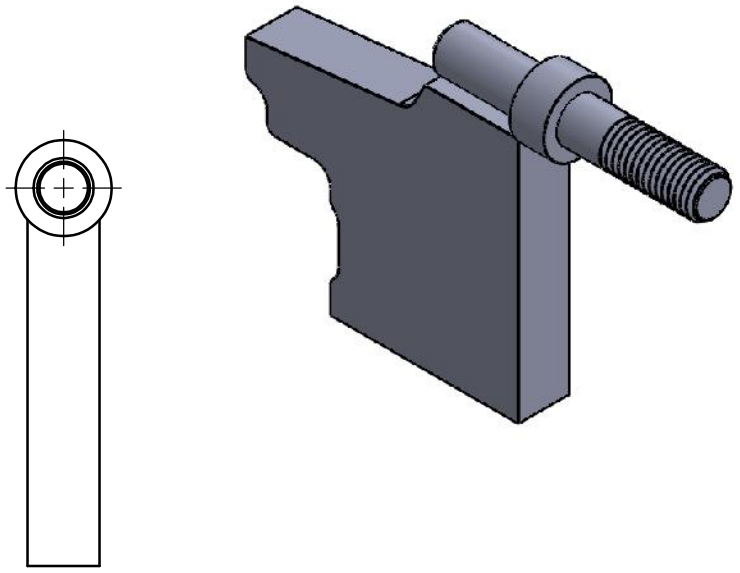
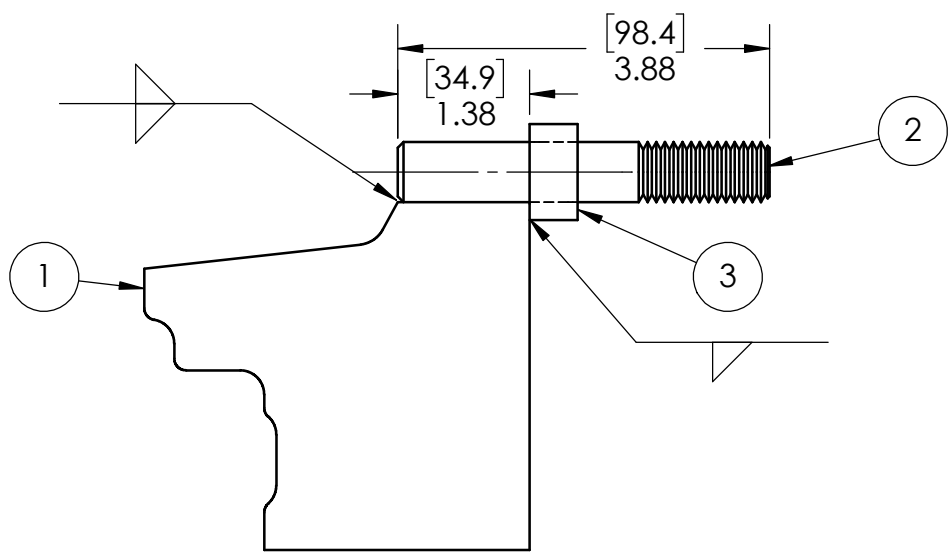
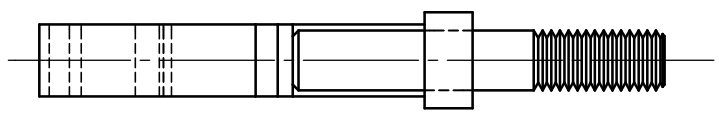

**DRAWING NOT FOR PRODUCTION USE**

A4	THIRD ANGLE PROJECTION	UNLESS OTHERWISE SPECIFIED:	NAME	DATE	
			DESIGN/ENGR C OBRIEN	2/2020	
DIMENSIONS: INCHES (MILLIMETERS)			DRAWN	9/2020	
			CHECKED	R JONES	
			REV A	R JONES	12/2021
			COMMENTS:		
			REV A: REVISED MOUNT, ADD WELDS		
		DO NOT SCALE DRAWING			

Insurance Institute for Highway Safety  
988 Dairy Rd, Ruckersville, VA 22968 (434) 985-4600

**LOWER SHOCK MOUNT ASSEMBLY**

SCALE: 1:2 | WEIGHT: 1.7 KG | SHEET 40 of 66



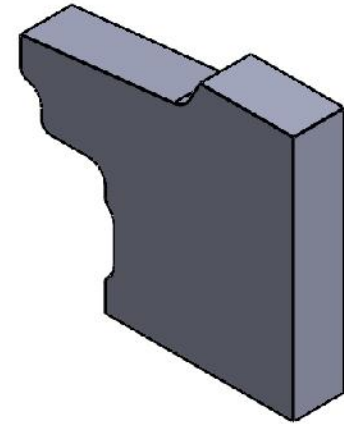
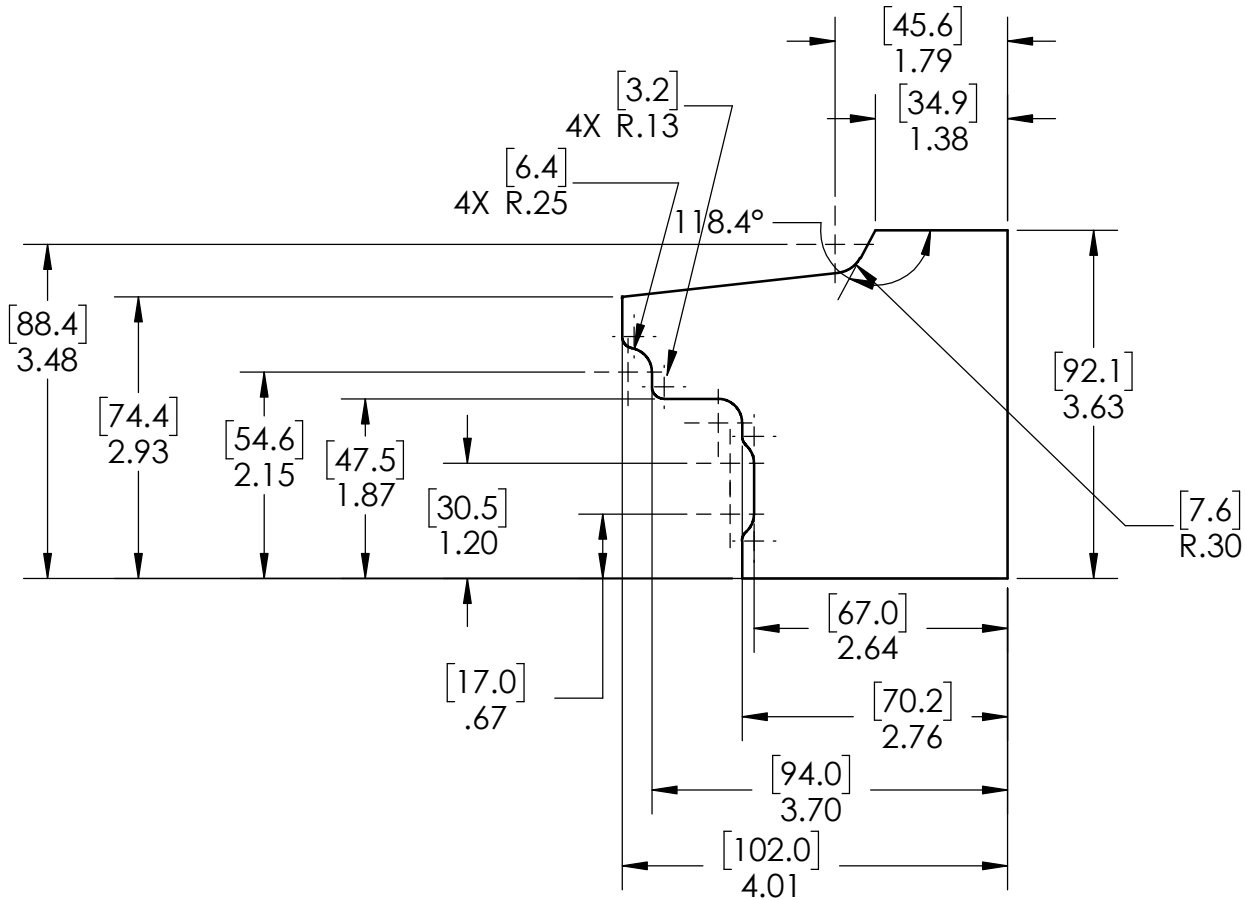

FROM .75" PLATE

**DRAWING NOT  
FOR PRODUCTION USE**

<b>A4</b>	THIRD ANGLE PROJECTION	UNLESS OTHERWISE SPECIFIED:	NAME	DATE
		MATERIAL	DESIGN/ENGR	C. O'BRIEN 2/2020
DIMENSIONS: INCHES (MILLIMETERS)		<b>ASTM A36</b>	DRAWN	W. SPIVEY 9/2020
			CHECKED	R. JONES 9/2020
			REV <b>A</b>	R. JONES 12/2021
			COMMENTS:	
			REV <b>A</b> : REVISED MODEL	
		DO NOT SCALE DRAWING		

Insurance Institute for Highway Safety  
988 Dairy Rd, Ruckersville, VA 22968 (434) 985-4600

**LOWER SHOCK  
MOUNT PLATE**

SCALE: 1:2 | WEIGHT: 1.2 KG | SHEET 41 of 66

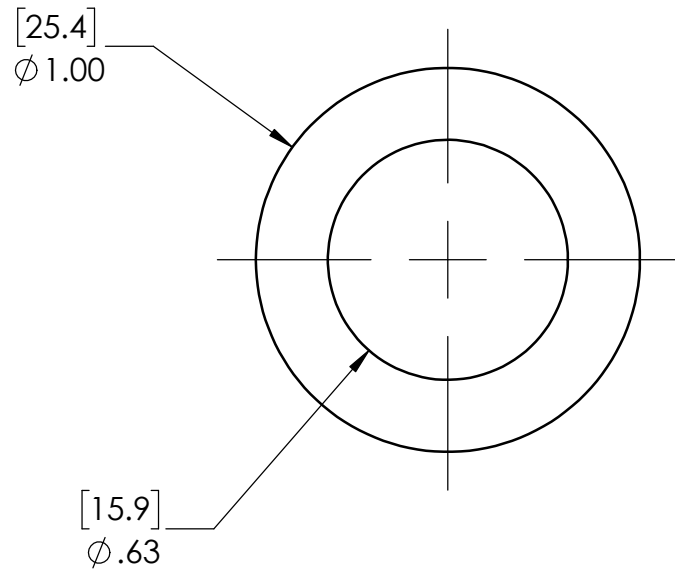

SHOCK SPACER

**DRAWING NOT  
FOR PRODUCTION USE**

<b>A4</b>	THIRD ANGLE PROJECTION 	<b>UNLESS OTHERWISE SPECIFIED:</b>			NAME	DATE	<b>Insurance Institute for Highway Safety</b> 988 Dairy Rd, Ruckersville, VA 22968 (434) 985-4600  <b>LOWER SHOCK MOUNT SPACER</b>
		MATERIAL	DESIGN/ENGR	C. O'BRIEN	2/2020		
DIMENSIONS: INCHES (MILLIMETERS)		<b>AISI 1018</b>	DRAWN	W. SPIVEY	9/2020		
			CHECKED	R. JONES	9/2020		
			REV <b>A</b>	R. JONES	12/2021		
			COMMENTS: REV <b>A</b> :REMOVE ROD END SPACER VIEWS				
		DO NOT SCALE DRAWING					
			SCALE: 2:1	WEIGHT: N/A	SHEET 42 of 66		

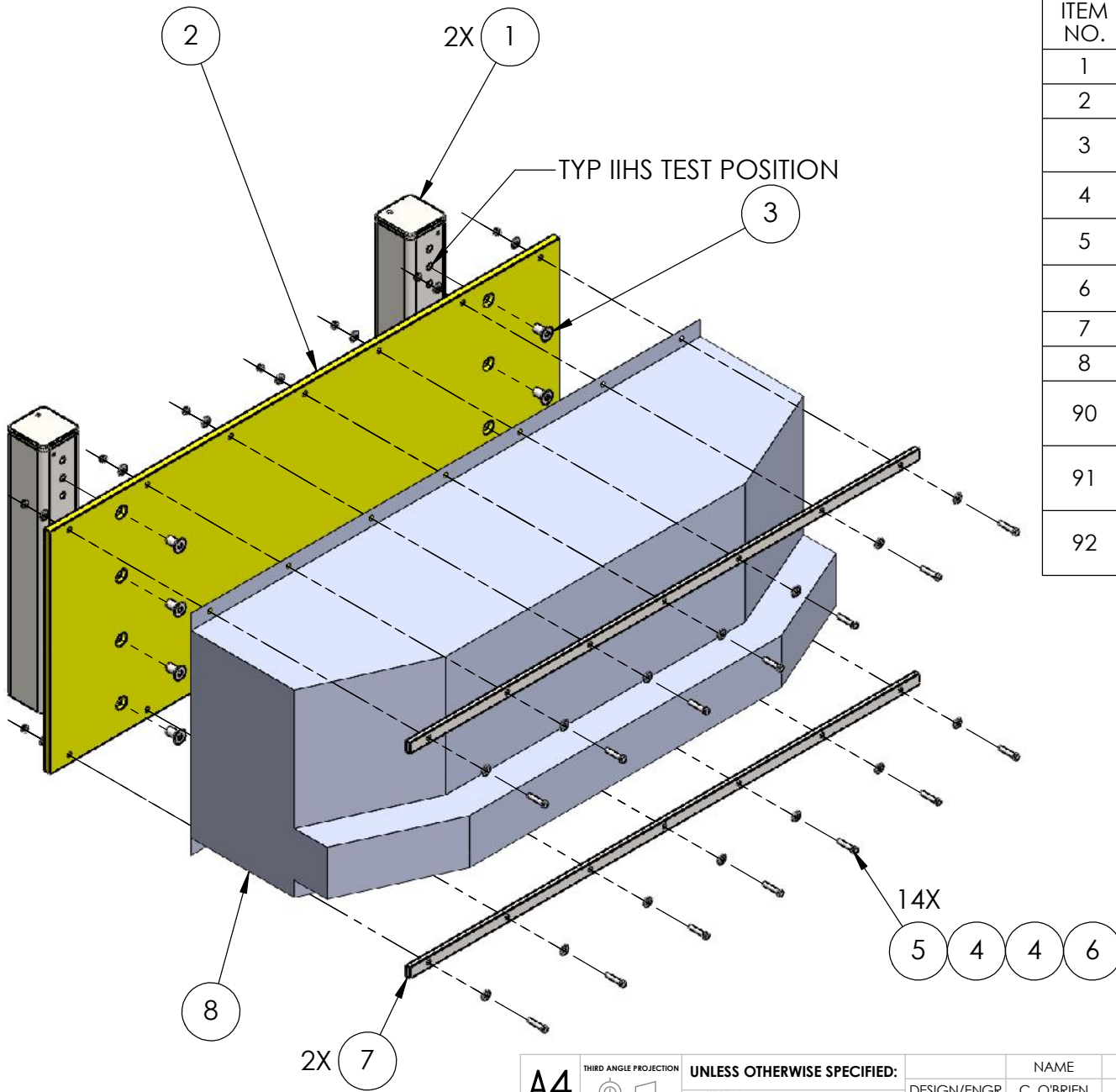

ITEM NO.	PART NUMBER	PAGE NUMBER	QTY.
1	BARRIER STANCHION	15	1
2	BARRIER MOUNTING PLATE	45	1
3	SCHCSCREW 0.75-16X1.5X1.5-HX-N		8
4	REGULAR FW 0.375		28
5	HBOLT 0.3750-16X2X1-N		14
6	HNUT 0.3750-16-D-N		14
7	BARRIER CLAMP BAR	47	2
8	DEFORMABLE BARRIER		1
90	HBOLT 0.5000-13X2.5X1.25-N		4
91	HBOLT 0.5000-13X3.5X1.25-N		6
92	HBOLT 0.5000-13X1.5X1.25-N		2

BARRIER BACKING PLATE HEIGHT ADJUSTABLE IN 2" INCREMENTS, FLIP FOR 1" INCREMENT

**DRAWING NOT FOR PRODUCTION USE**

A4	THIRD ANGLE PROJECTION	UNLESS OTHERWISE SPECIFIED:		NAME	DATE
		MATERIAL		DESIGN/ENGR	C. O'BRIEN 2/2020
DIMENSIONS: INCHES (MILLIMETERS)		N/A		DRAWN	W. SPIVEY 9/2020
				CHECKED	R. JONES 9/2020
				REV A	R. JONES 12/2021
				COMMENTS: REV A: NO CHANGES	
		DO NOT SCALE DRAWING			

Insurance Institute for Highway Safety  
988 Dairy Rd, Ruckersville, VA 22968 (434) 985-4600

## FRONT BARRIER ASSEMBLY

SCALE: 1:15 WEIGHT: 238 KG SHEET 43 of 66

ITEM NO.	PART NUMBER	PAGE NUMBER	QTY.
1	BARRIER MOUNTING PLATE	45	1
2	MOUNTING PLATE RIB	46	2

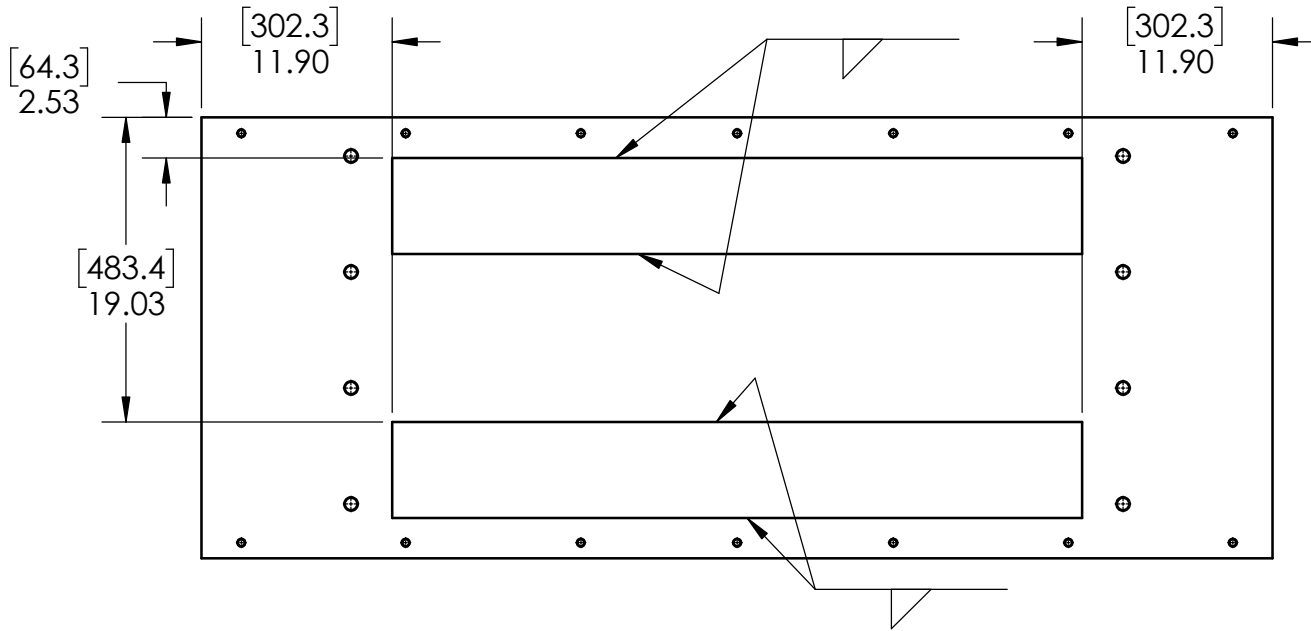
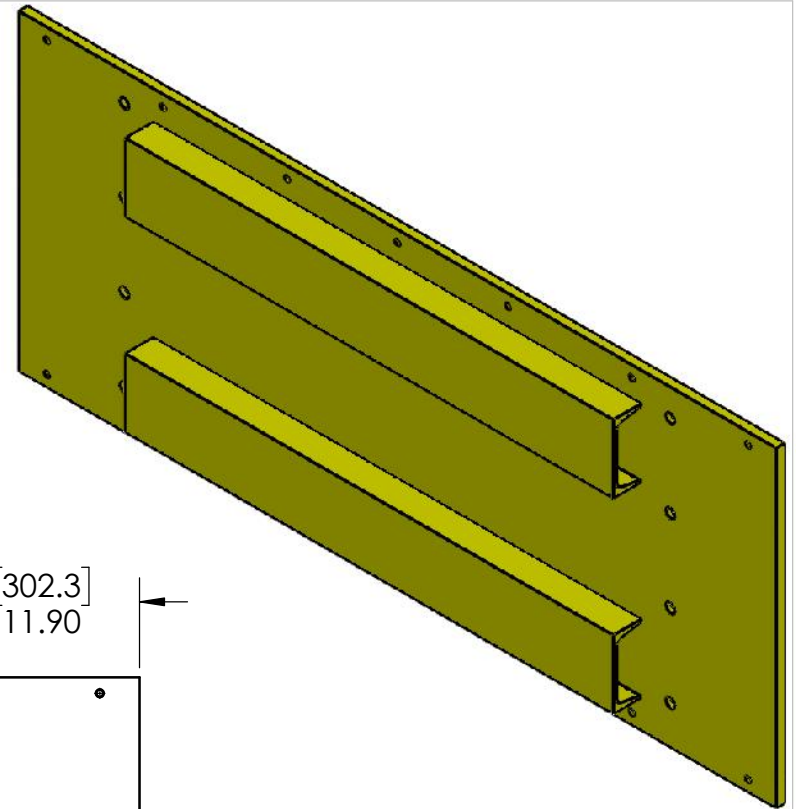

**DRAWING NOT FOR PRODUCTION USE**

A4	THIRD ANGLE PROJECTION	UNLESS OTHERWISE SPECIFIED:	NAME	DATE
		MATERIAL	DESIGN/ENGR	C. O'BRIEN 2/2020
DIMENSIONS: INCHES (MILLIMETERS)		N/A	DRAWN	W. SPIVEY 9/2020
			CHECKED	R. JONES 9/2020
			REV A	R. JONES 12/2021
			COMMENTS:	
			REV A: ADD WELDS	
		DO NOT SCALE DRAWING		

Insurance Institute for Highway Safety  
988 Dairy Rd, Ruckersville, VA 22968 (434) 985-4600

## BARRIER MOUNTING PLATE RIB PLACEMENT

SCALE: 1:12 | WEIGHT: N/A | SHEET 44 of 66

5

4

3

2

1

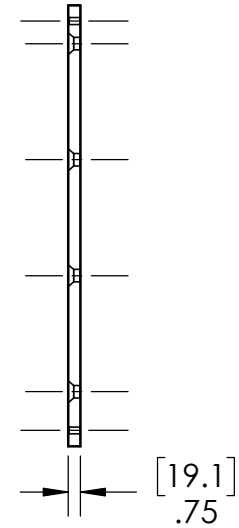
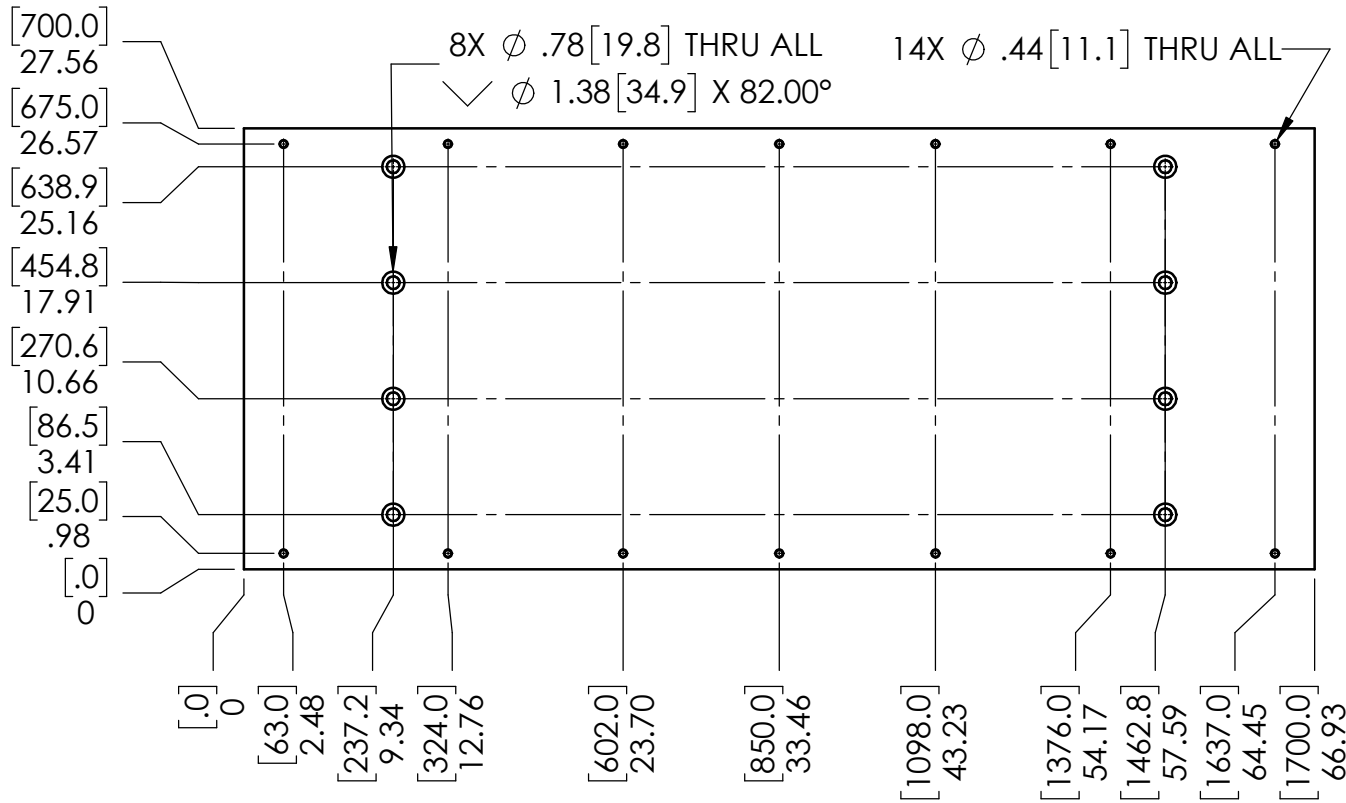
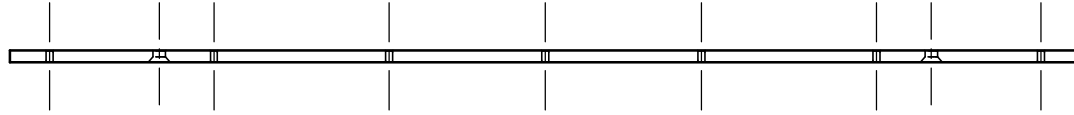
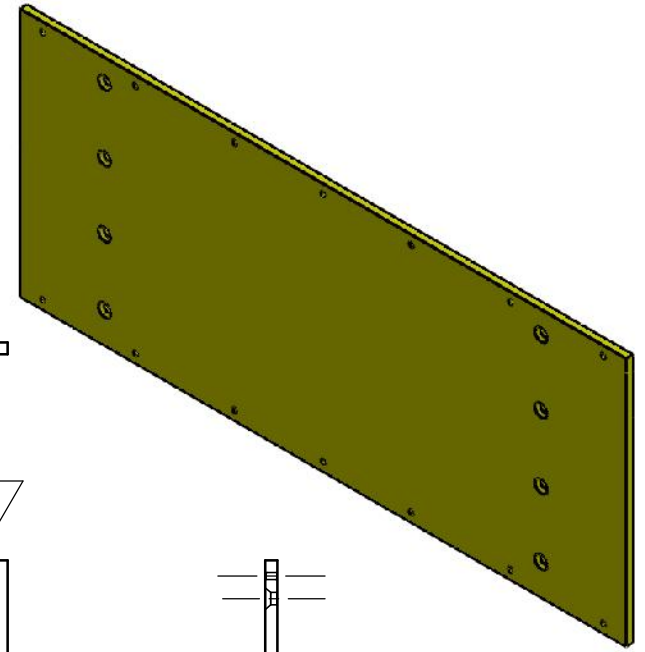

**DRAWING NOT  
FOR PRODUCTION USE**

<b>A4</b>	THIRD ANGLE PROJECTION	<b>UNLESS OTHERWISE SPECIFIED:</b>	NAME	DATE
			DESIGN/ENGR C. O'BRIEN	2/2020
DIMENSIONS: INCHES (MILLIMETERS)		MATERIAL	DRAWN	9/2020
		<b>ASTM A36</b>	W. SPIVEY	9/2020
			CHECKED	9/2020
			R. JONES	9/2020
			REV A	12/2021
			COMMENTS: REV A: NO CHANGES	
		DO NOT SCALE DRAWING		

**Insurance Institute for Highway Safety**  
988 Dairy Rd, Ruckersville, VA 22968 (434) 985-4600

# BARRIER MOUNTING PLATE

SCALE: 1:12    WEIGHT: 176 KG    SHEET 45 of 66



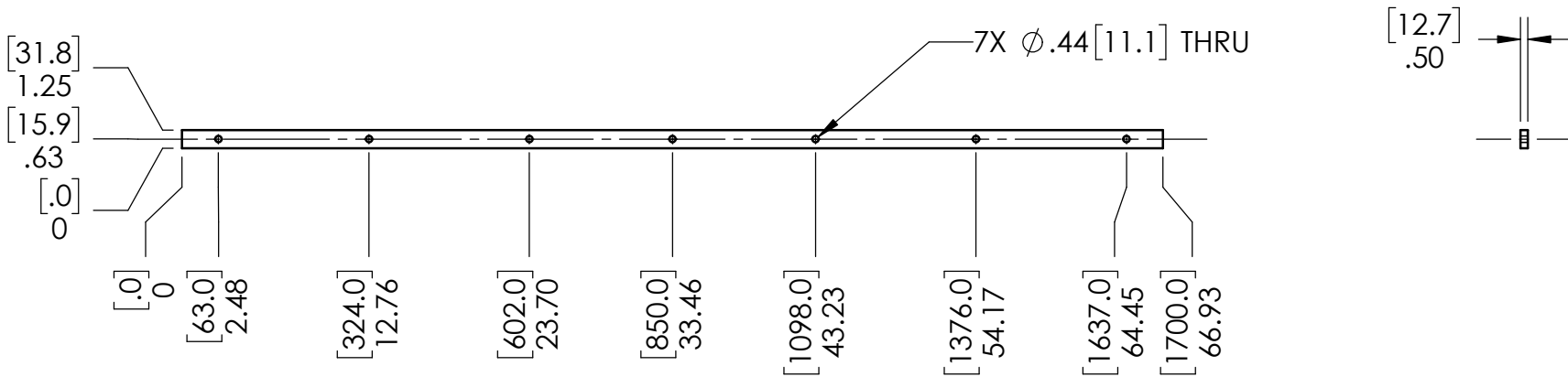
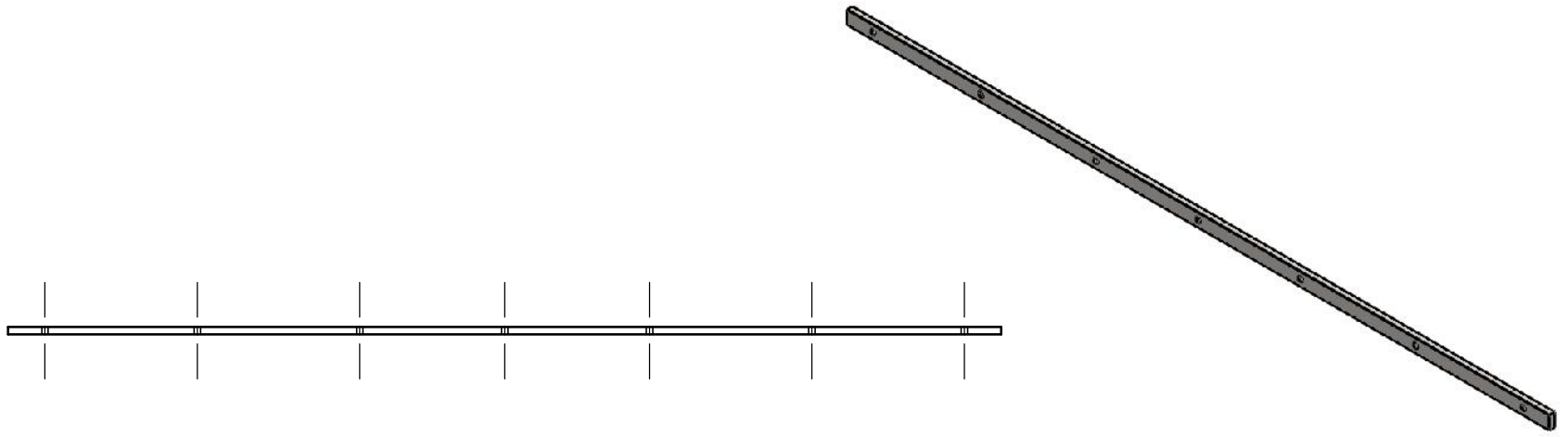

FROM .5X.125 BAR

**DRAWING NOT  
FOR PRODUCTION USE**

<b>A4</b>	THIRD ANGLE PROJECTION	<b>UNLESS OTHERWISE SPECIFIED:</b>	NAME	DATE
		MATERIAL	DESIGN/ENGR	
DIMENSIONS: INCHES (MILLIMETERS)		<b>ASTM A36</b>	C. O'BRIEN	2/2020
			W. SPIVEY	9/2020
			R. JONES	9/2020
			REV A	12/2021
			COMMENTS:	
		DO NOT SCALE DRAWING	REV A: NO CHANGES	

Insurance Institute for Highway Safety		
988 Dairy Rd, Ruckersville, VA 22968 (434) 985-4600		
<b>BARRIER CLAMP BAR</b>		
SCALE: 1:12	WEIGHT: 5.3 KG	SHEET 47 of 66

5

4

3

2

1

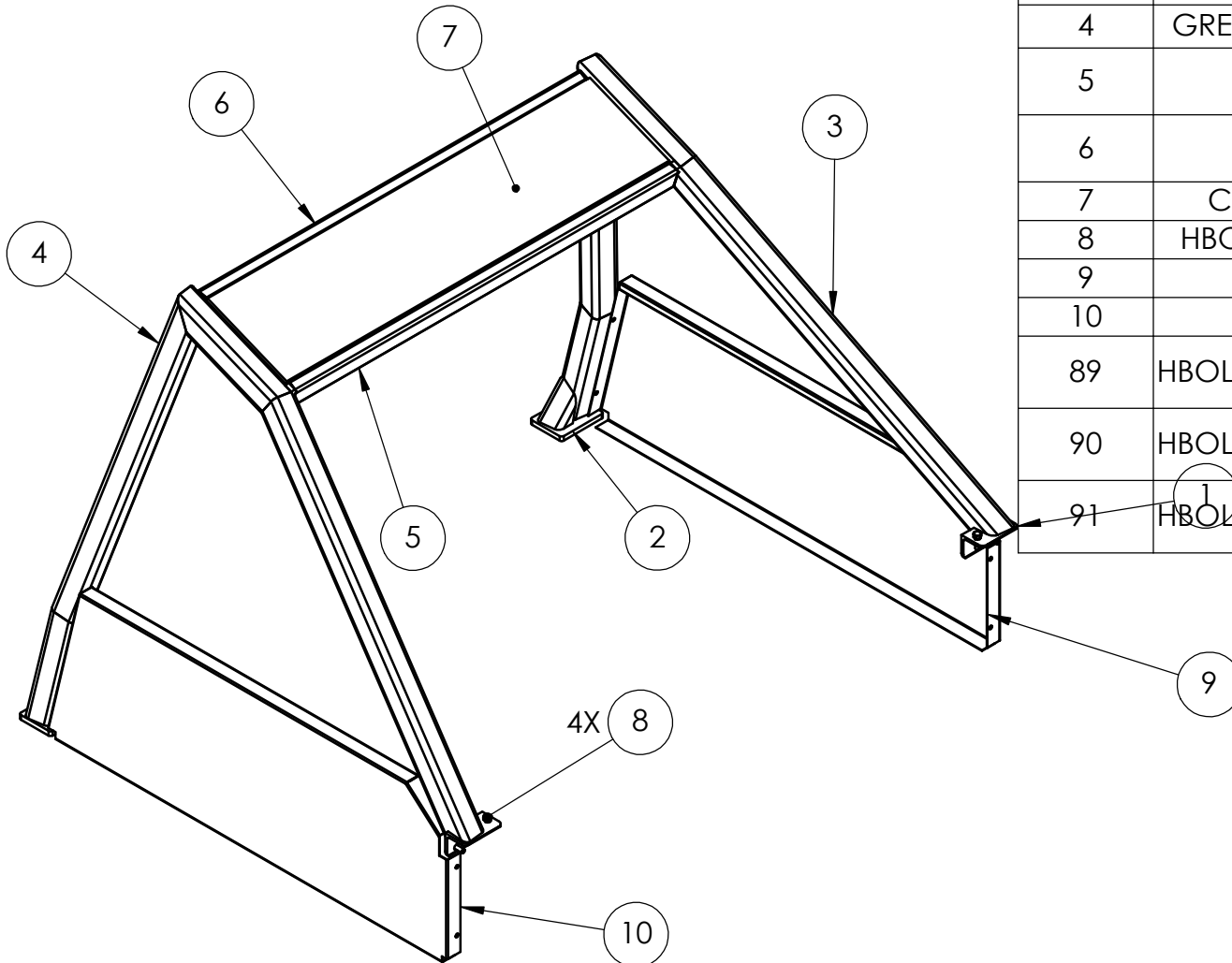

ITEM NO.	PART NUMBER	PAGE NUMBER	QTY.
1	GREENHOUSE FRONT TAB, LEFT AND RIGHT	50	1
2	GREENHOUSE REAR TAB	51	1
3	GREENHOUSE TUBING LEFT	49	1
4	GREENHOUSE TUBING, RIGHT	49	1
5	FRT CAM PLATE CROSSMEMBER	49	1
6	REAR CAM PLATE CROSSMEMBER	49	1
7	CAMERA MOUNT PLATE	52	1
8	HBOLT 0.3125-18X1X0.875-N		4
9	LEFT SIGN PLATE	53	1
10	RIGHT SIGN PLATE	53	1
89	HBOLT 0.5000-13X2.5X1.25-N		4
90	HBOLT 0.5000-13X3.5X1.25-N		6
91	HBOLT 0.5000-13X1.5X1.25-N		2

**DRAWING NOT FOR PRODUCTION USE**

<b>A4</b>	THIRD ANGLE PROJECTION	<b>UNLESS OTHERWISE SPECIFIED:</b>	NAME	DATE
		MATERIAL	DESIGN/ENGR	C. O'BRIEN 2/2020
DIMENSIONS: INCHES [MILLIMETERS]		N/A	DRAWN	W. SPIVEY 9/2020
			CHECKED	R. JONES 9/2020
			REV A	R. JONES 12/2021
			COMMENTS:	
			REV A: NO CHANGES	
		DO NOT SCALE DRAWING		

**Insurance Institute for Highway Safety**  
 988 Dairy Rd, Ruckersville, VA 22968 (434) 985-4600

**GREENHOUSE ASSEMBLY**

SCALE: 1:12 | WEIGHT: 42 KG | SHEET 48 of 66



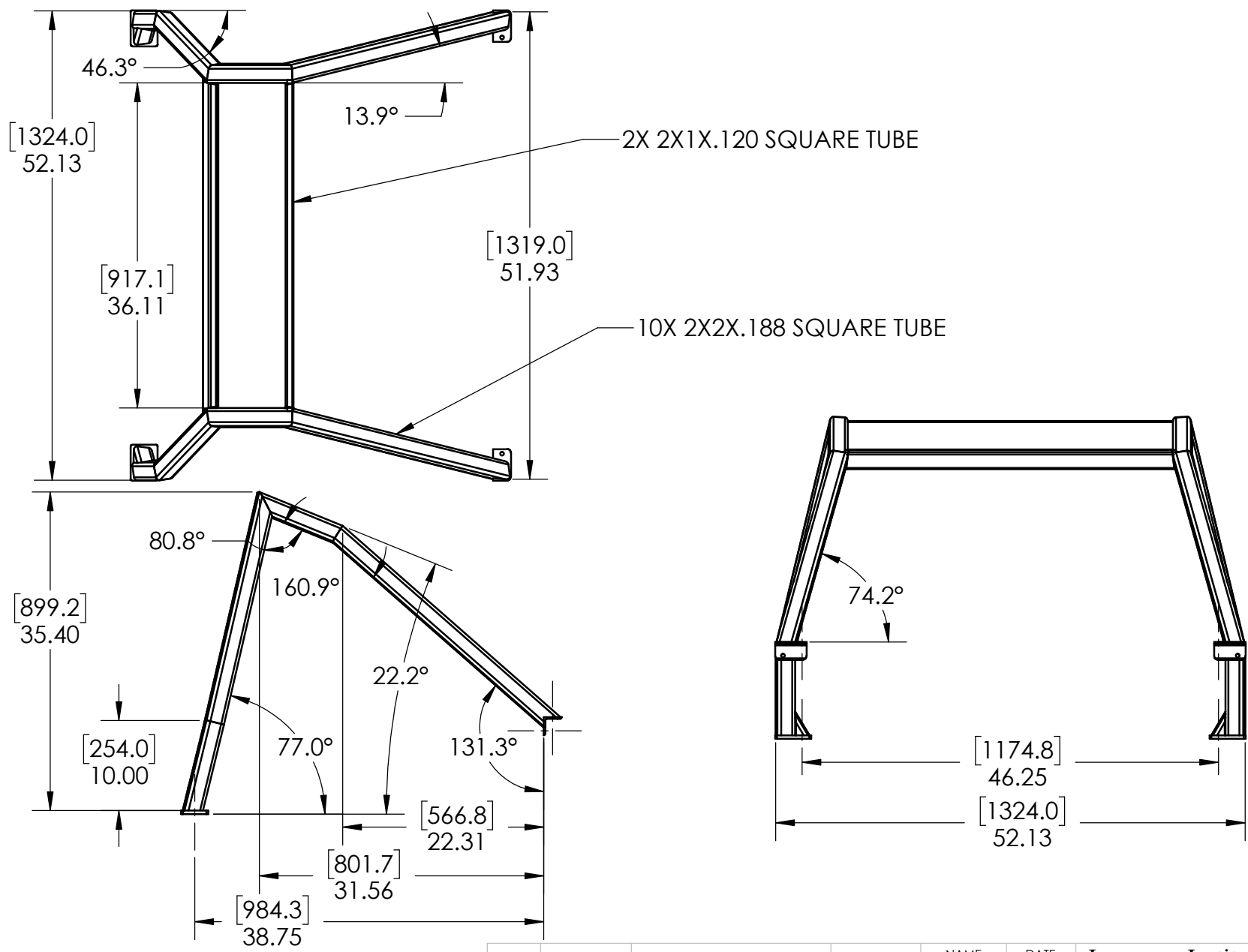

**DRAWING NOT  
FOR PRODUCTION USE**

<b>A4</b>	THIRD ANGLE PROJECTION	<b>UNLESS OTHERWISE SPECIFIED:</b>	NAME	DATE
	DIMENSIONS: INCHES (MILLIMETERS)	MATERIAL	DESIGN/ENGR	
		<b>ASTM A500 &amp; A36</b>	C. O'BRIEN	2/2020
			DRAWN	W. SPIVEY
			CHECKED	R. JONES
			REV A	R. JONES
			COMMENTS:	12/2021
			REV A: NO CHANGES	
		DO NOT SCALE DRAWING		

Insurance Institute for Highway Safety		
988 Dairy Rd, Ruckersville, VA 22968 (434) 985-4600		
<b>GREENHOUSE DIMENSIONS</b>		
SCALE: 1:16	WEIGHT: 42 KG	SHEET 49 of 66

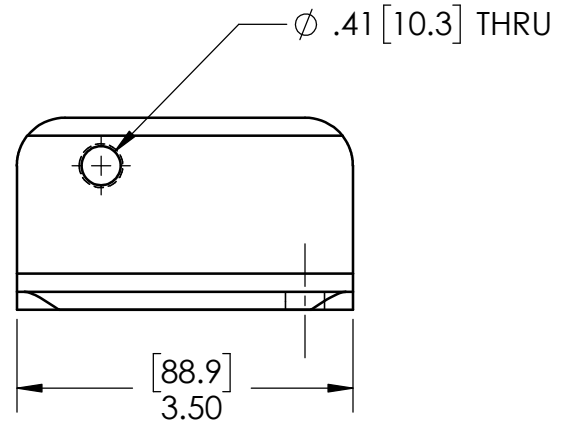
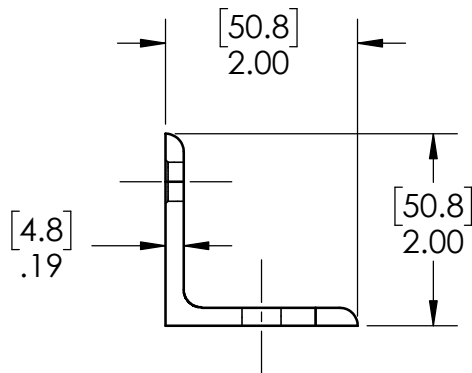
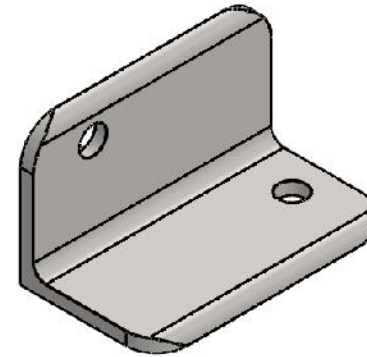
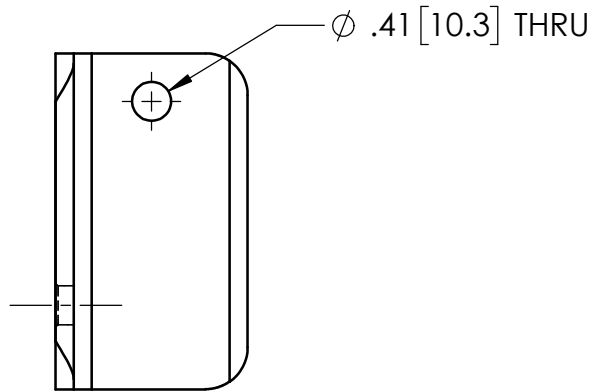

LEFT SHOWN RIGHT SIMILAR  
FROM 2x2x.188 ANGLE  
ROUND CORNERS

**DRAWING NOT  
FOR PRODUCTION USE**

<b>A4</b>	THIRD ANGLE PROJECTION	<b>UNLESS OTHERWISE SPECIFIED:</b>		NAME	DATE
		MATERIAL	<b>ASTM A36</b>	DESIGN/ENGR	C. O'BRIEN 2/2020
DIMENSIONS: INCHES (MILLIMETERS)				DRAWN	W. SPIVEY 9/2020
				CHECKED	R. JONES 9/2020
				REV <b>A</b>	R. JONES 12/2021
				COMMENTS:	
				REV <b>A</b> : NO CHANGES	
				DO NOT SCALE DRAWING	

Insurance Institute for Highway Safety  
988 Dairy Rd, Ruckersville, VA 22968 (434) 985-4600

**GREENHOUSE FRONT  
TAB**

SCALE: 1:2 | WEIGHT: 0.3 KG | SHEET 50 of 66

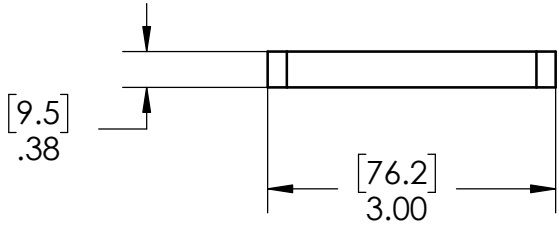
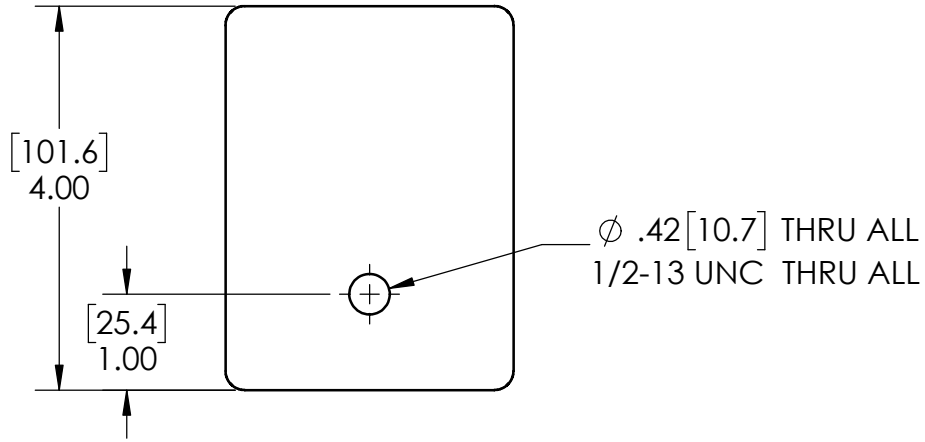
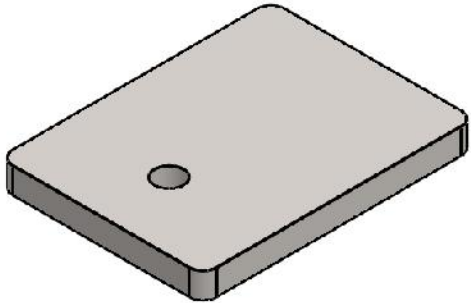

FROM .375X3 BAR

**DRAWING NOT FOR PRODUCTION USE**

<b>A4</b>	THIRD ANGLE PROJECTION	<b>UNLESS OTHERWISE SPECIFIED:</b>		NAME	DATE
		MATERIAL	<b>AISI 1018</b>	DESIGN/ENGR	C. O'BRIEN 2/2020
DIMENSIONS: INCHES (MILLIMETERS)		DO NOT SCALE DRAWING		DRAWN	W. SPIVEY 9/2020
				CHECKED	R. JONES 9/2020
				REV A	R. JONES 12/2021
				COMMENTS:	
				REV A: NO CHANGES	

Insurance Institute for Highway Safety  
 988 Dairy Rd, Ruckersville, VA 22968 (434) 985-4600

**GREENHOUSE REAR TAB**

SCALE: 1:2 | WEIGHT: 0.6 KG | SHEET 51 of 66

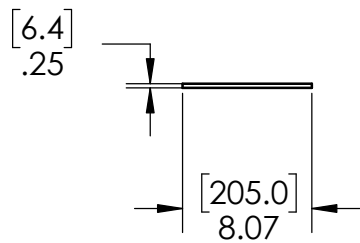
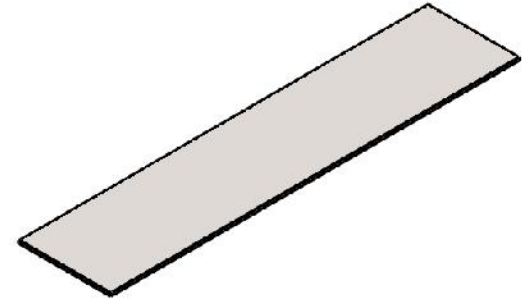
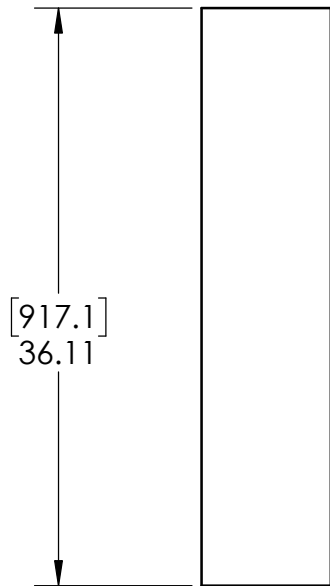

**DRAWING NOT  
FOR PRODUCTION USE**

<b>A4</b>	THIRD ANGLE PROJECTION 	<b>UNLESS OTHERWISE SPECIFIED:</b>			NAME	DATE	Insurance Institute for Highway Safety 988 Dairy Rd, Ruckersville, VA 22968 (434) 985-4600
		MATERIAL	DESIGN/ENGR	C. O'BRIEN	2/2020		
DIMENSIONS: INCHES (MILLIMETERS)		<b>ASTM A36</b>	DRAWN	W. SPIVEY	9/2020	<b>CAMERA MOUNT PLATE</b>	
			CHECKED	R. JONES	9/2020		
			REV A	R. JONES	12/2021		
			COMMENTS: REV A: NO CHANGES				
		DO NOT SCALE DRAWING					SCALE: 1:12   WEIGHT: 9.3 KG   SHEET 52 of 66

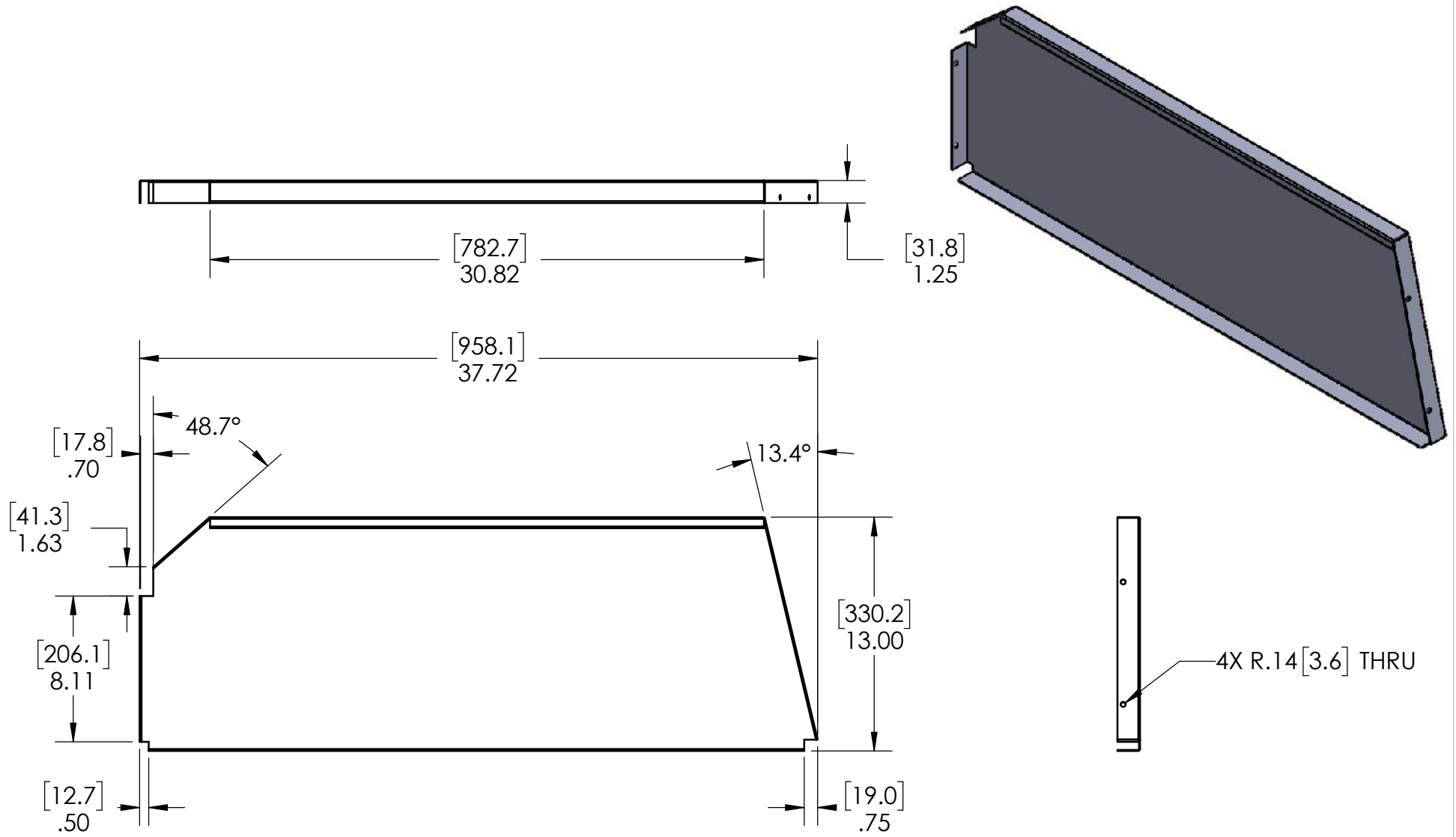

RIGHT SIDE SHOWN  
LEFT SIDE SIMILAR

**DRAWING NOT  
FOR PRODUCTION USE**

<b>A4</b>	THIRD ANGLE PROJECTION	<b>UNLESS OTHERWISE SPECIFIED:</b>	NAME	DATE
		MATERIAL	DESIGN/ENGR	
DIMENSIONS: INCHES (MILLIMETERS)		<b>16 GA ASTM A653</b>	C. O'BRIEN	2/2020
			DRAWN	W. SPIVEY
			CHECKED	R. JONES
			REV <b>A</b>	R. JONES
			COMMENTS:	12/2021
			REV <b>A</b> : NO CHANGES	
		DO NOT SCALE DRAWING		

**Insurance Institute for Highway Safety**  
988 Dairy Rd, Ruckersville, VA 22968 (434) 985-4600

**SIGN PLATE**

SCALE: 1:8    WEIGHT: 0.1 KG    SHEET 53 of 66

ITEM NO.	PART NUMBER	PAGE NUMBER	QTY.
1	BALLAST PLATE FRONT	62	2
2	BALLAST PLATE REAR	63	1
3	BALLAST WEIGHT STACK	55	2
4	Z CHANNEL	5, 6	1 EA

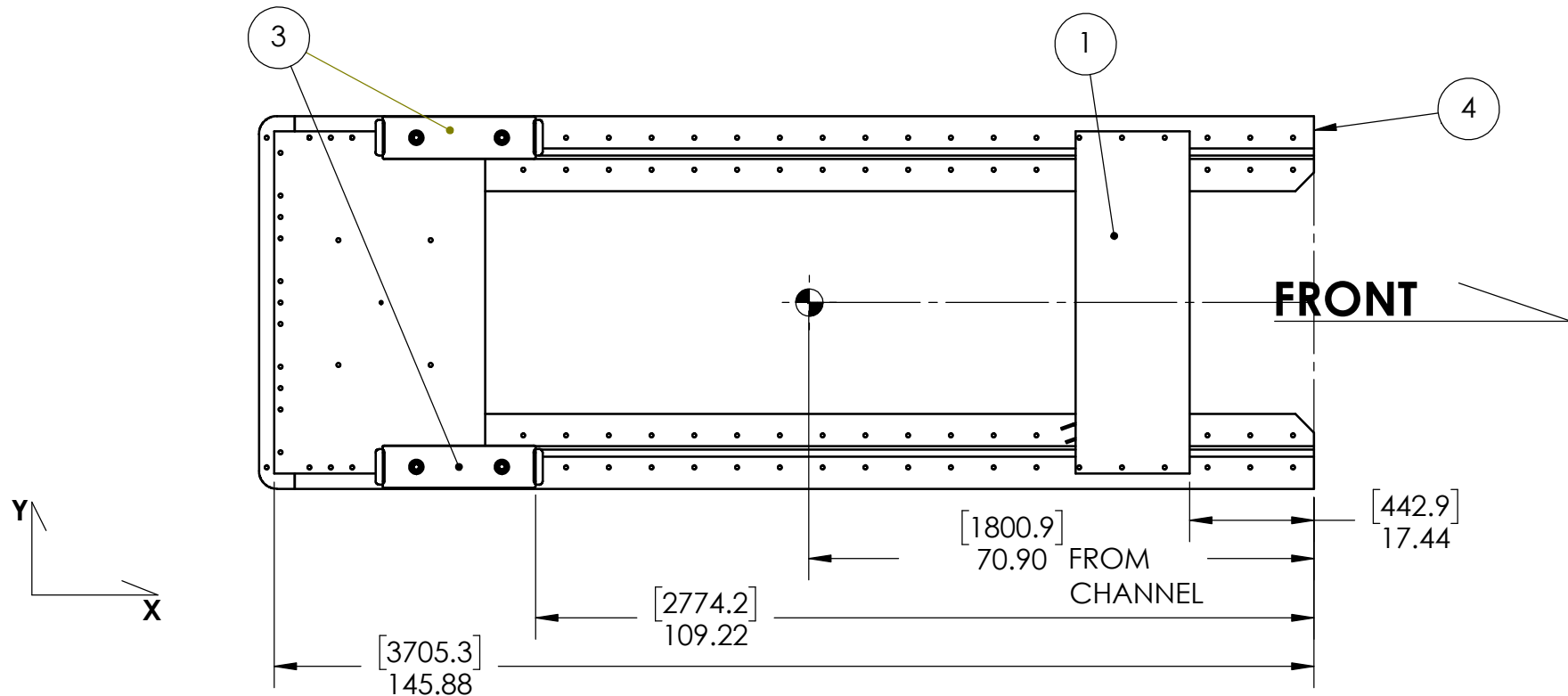

ENTIRE CART CG AND MOMENTS AS MEASURED BEHIND AND ABOVE FRONT AXLE AT TIRE CONTACT POINT WITH GROUND	CGX (MM)	CGY (MM)	CGZ (MM)	IXX (KG/M2)	IYY (KG/M2)	IZZ (KG/M2)
	1236.4	2.0	650.7	581	3688	4049

**DRAWING NOT FOR PRODUCTION USE**

A4	THIRD ANGLE PROJECTION	UNLESS OTHERWISE SPECIFIED:	NAME	DATE	
		MATERIAL	DESIGN/ENGR	C. O'BRIEN	2/2020
DIMENSIONS: INCHES (MILLIMETERS)		N/A	DRAWN	W. SPIVEY	9/2020
			CHECKED	R. JONES	9/2020
			REV A	R. JONES	12/2021
			COMMENTS:		
			REV A: NO CHANGES		
		DO NOT SCALE DRAWING			

Insurance Institute for Highway Safety  
988 Dairy Rd, Ruckersville, VA 22968 (434) 985-4600

## BALLAST WEIGHT PLACEMENT

SCALE: 1:24 WEIGHT: N/A SHEET 54 of 66

ITEM NO.	PART NUMBER	PAGE NUMBER	QTY.
1	BASE PLATE	56	1
2	20 KG PLATE	57	2
3	10.1 KG PLATE	58	1
4	8.1 KG PLATE	59	1
5	1"-5 X 7.25" ACME THREADED ROD		2
7	FLAT WASHER 1"		2
8	HNUT 1.0000-5 ACME		2
6	SCHCSCREW 0.5-13X2.5X1.5-HX-N		4

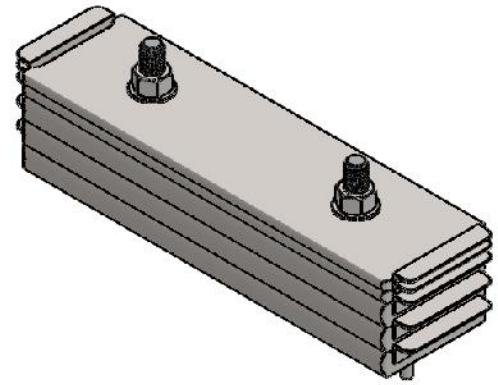
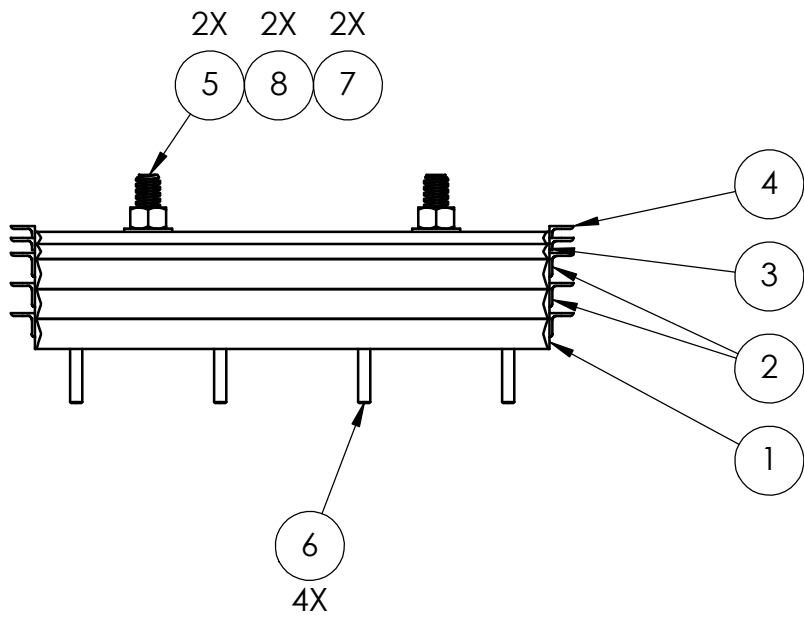

**DRAWING NOT FOR PRODUCTION USE**

A4	THIRD ANGLE PROJECTION	UNLESS OTHERWISE SPECIFIED:	NAME	DATE
		MATERIAL	DESIGN/ENGR	C. O'BRIEN 2/2020
DIMENSIONS: INCHES (MILLIMETERS)		N/A	DRAWN	W. SPIVEY 9/2020
			CHECKED	R. JONES 9/2020
			REV A	R. JONES 12/2021
			COMMENTS:	
			REV A: NO CHANGES	
		DO NOT SCALE DRAWING		

Insurance Institute for Highway Safety  
988 Dairy Rd, Ruckersville, VA 22968 (434) 985-4600

# BALLAST WEIGHT STACK

SCALE: 1:8 | WEIGHT: 79 KG | SHEET 55 of 66

ITEM NO.	PART NUMBER	PAGE NUMBER	QTY.
2	BALLAST PLATE HANDLES LONG	60	2

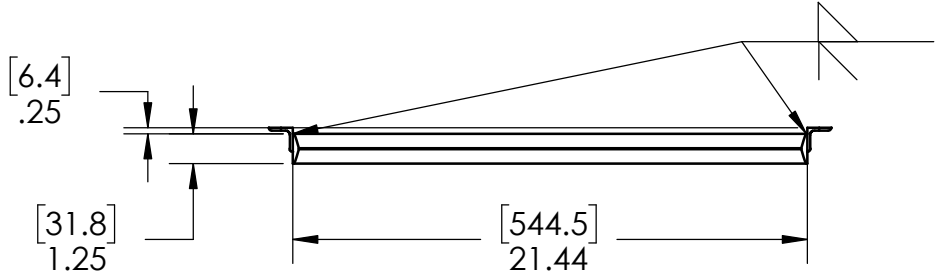
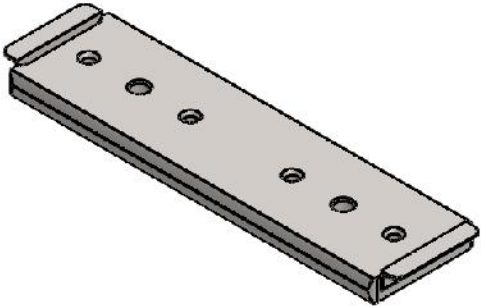
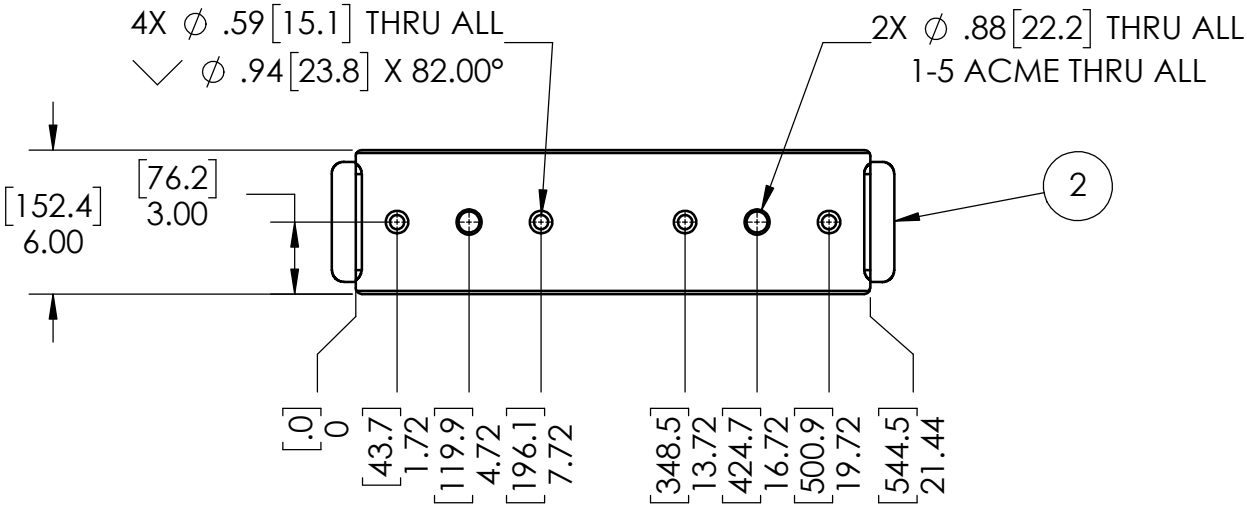

FROM 1.25X6 BAR

**DRAWING NOT FOR PRODUCTION USE**

A4	THIRD ANGLE PROJECTION	UNLESS OTHERWISE SPECIFIED:	NAME	DATE
		MATERIAL	DESIGN/ENGR	
DIMENSIONS: INCHES (MILLIMETERS)		HR A36	C. O'BRIEN	2/2020
			W. SPIVEY	9/2020
			R. JONES	9/2020
			R. JONES	12/2021
			COMMENTS:	
			REV A: ADD WELD	
		DO NOT SCALE DRAWING		

Insurance Institute for Highway Safety  
 988 Dairy Rd, Ruckersville, VA 22968 (434) 985-4600

**BALLAST PLATE BASE**

SCALE: 1:8 WEIGHT: 20 KG SHEET 56 of 66



ITEM NO.	PART NUMBER	PAGE NUMBER	QTY.
2	BALLAST PLATE HANDLES LONG	60	2

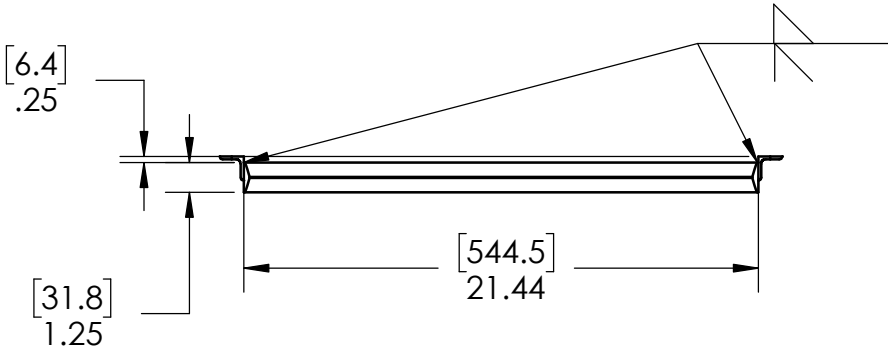
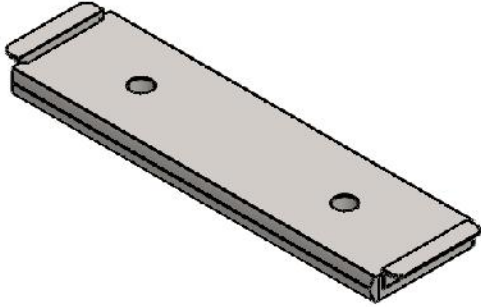
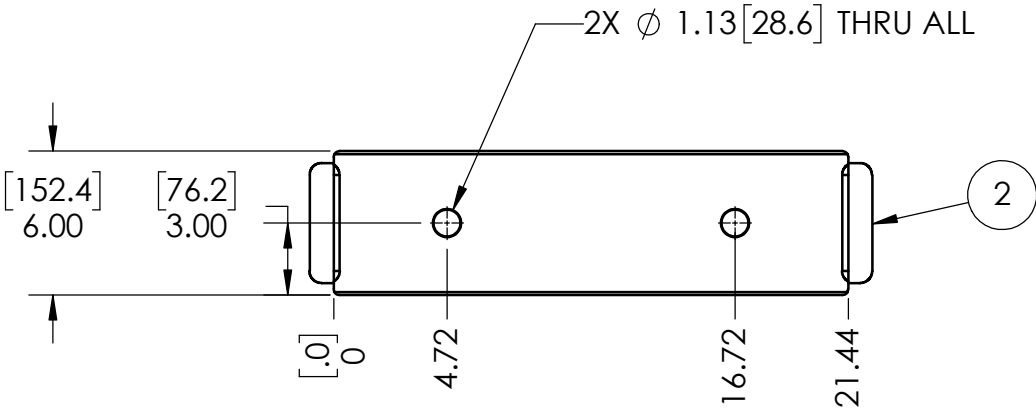

FROM 1.25X6 BAR

**DRAWING NOT  
FOR PRODUCTION USE**

A4	THIRD ANGLE PROJECTION	UNLESS OTHERWISE SPECIFIED:	NAME	DATE
		MATERIAL	DESIGN/ENGR	
DIMENSIONS: INCHES (MILLIMETERS)		HR A36	C. O'BRIEN	2/2020
			W. SPIVEY	9/2020
			R. JONES	9/2020
			R. JONES	12/2021
			COMMENTS:	
			REV A: ADD WELD	
		DO NOT SCALE DRAWING		

Insurance Institute for Highway Safety  
988 Dairy Rd, Ruckersville, VA 22968 (434) 985-4600

**BALLAST PLATE 20KG**

SCALE: 1:8 WEIGHT: 20 KG SHEET 57 of 66

ITEM NO.	PART NUMBER	PAGE NUMBER	QTY.
2	BALLAST PLATE HANDLE SHORT	61	2

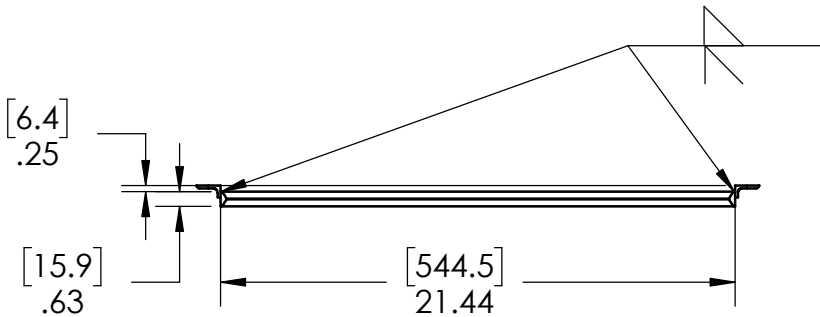
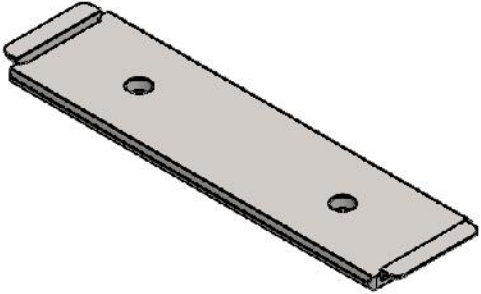
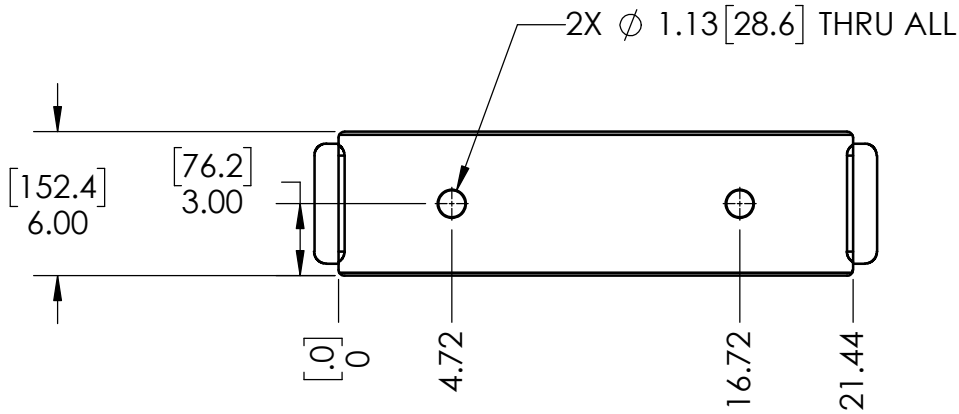

FROM .625X6 BAR

**DRAWING NOT FOR PRODUCTION USE**

<b>A4</b>	THIRD ANGLE PROJECTION	UNLESS OTHERWISE SPECIFIED:	NAME	DATE
		MATERIAL	DESIGN/ENGR	
DIMENSIONS: INCHES (MILLIMETERS)		<b>HR A36</b>	C. O'BRIEN	2/2020
			W. SPIVEY	9/2020
DO NOT SCALE DRAWING			R. JONES	9/2020
			R. JONES	12/2021
		COMMENTS:		
			REV A: ADD WELD	

Insurance Institute for Highway Safety  
988 Dairy Rd, Ruckersville, VA 22968 (434) 985-4600

**BALLAST PLATE 10.1KG**

SCALE: 1:8 WEIGHT: 10.1 KG SHEET 58 of 66

ITEM NO.	PART NUMBER	PAGE NUMBER	QTY.
2	BALLAST PLATE HANDLE SHORT	61	2

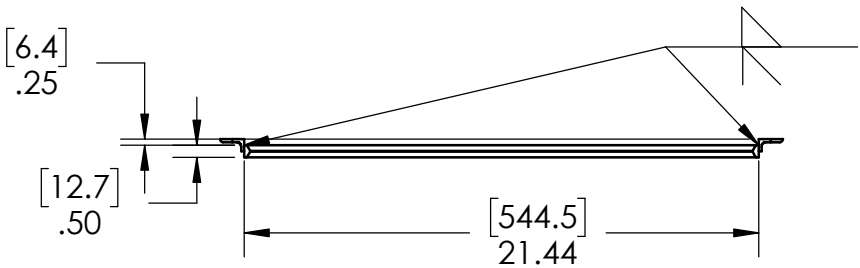
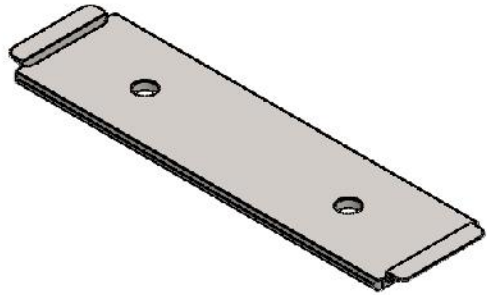
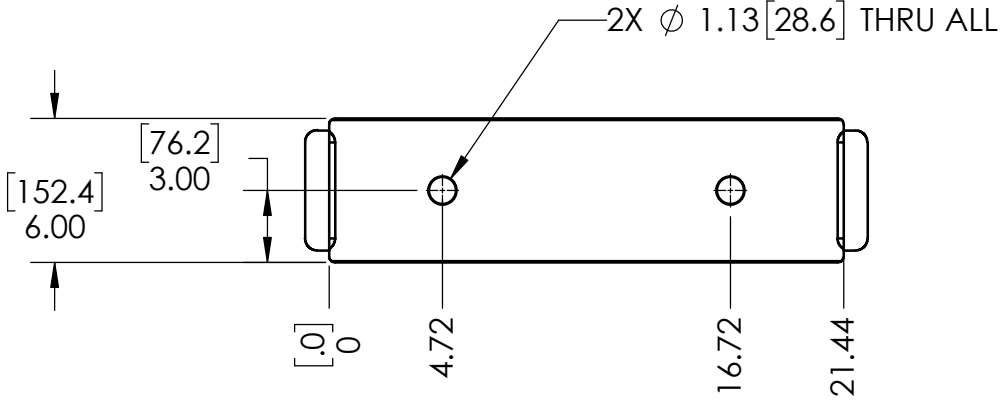

FROM .5X6 BAR  
**DRAWING NOT  
FOR PRODUCTION USE**

A4	THIRD ANGLE PROJECTION	UNLESS OTHERWISE SPECIFIED:	NAME	DATE
		MATERIAL	DESIGN/ENGR	C. O'BRIEN 2/2020
DIMENSIONS: INCHES (MILLIMETERS)		HR A36	DRAWN	W. SPIVEY 9/2020
			CHECKED	R. JONES 9/2020
			REV A	R. JONES 12/2021
			COMMENTS:	
		DO NOT SCALE DRAWING	REV A: ADD WELD	

Insurance Institute for Highway Safety  
988 Dairy Rd, Ruckersville, VA 22968 (434) 985-4600

**BALLAST PLATE 8.1KG**

SCALE: 1:8 WEIGHT: 8.1 KG SHEET 59 of 66

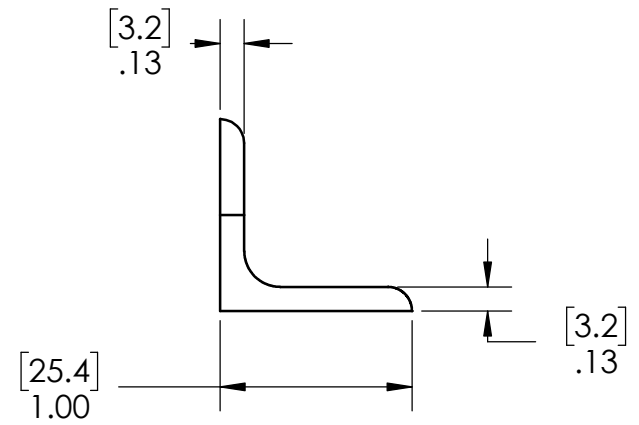
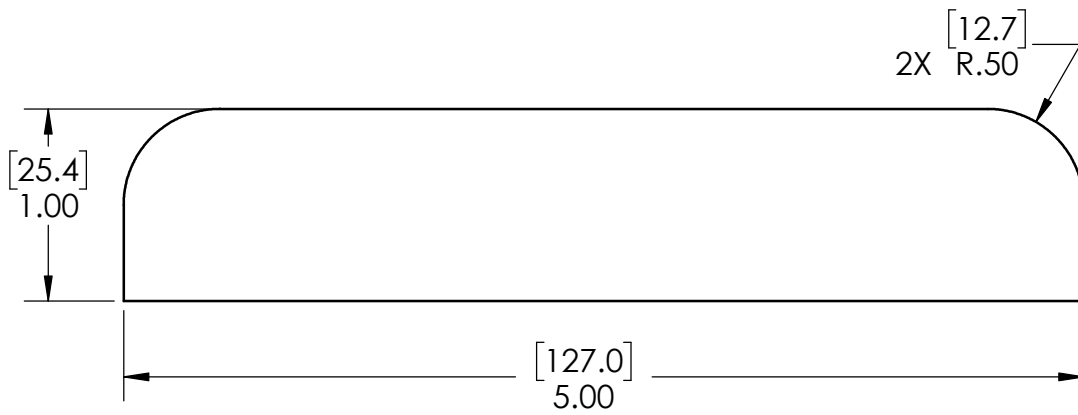
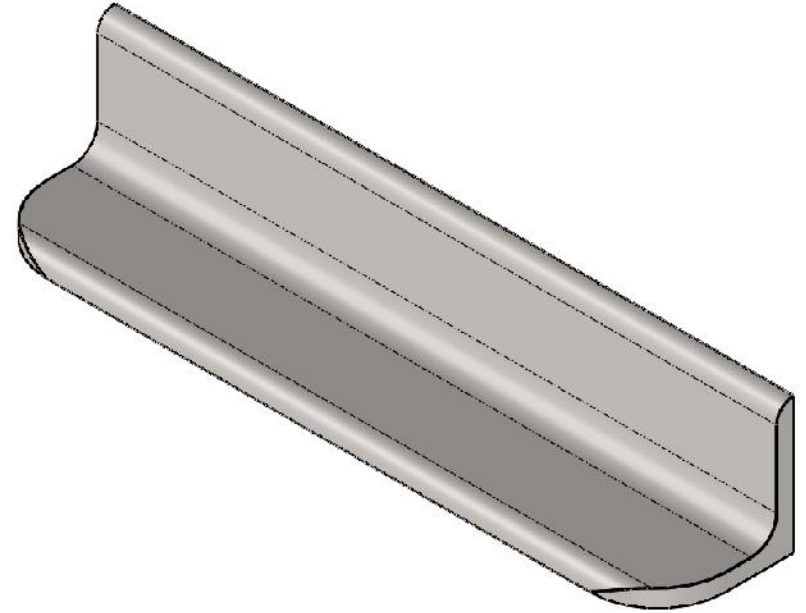
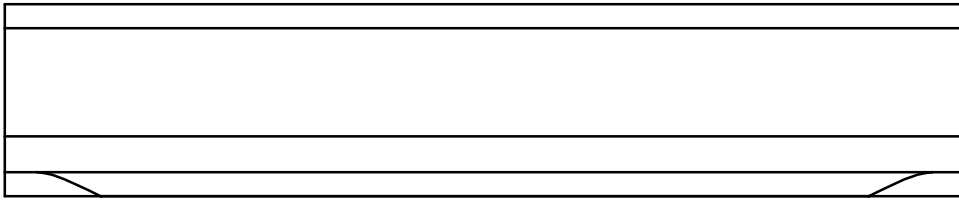

FROM 1X1X.125 ANGLE  
**DRAWING NOT  
 FOR PRODUCTION USE**

<b>A4</b>	THIRD ANGLE PROJECTION	<b>UNLESS OTHERWISE SPECIFIED:</b>		NAME	DATE
		MATERIAL	<b>ASTM A36</b>	DESIGN/ENGR	C. O'BRIEN 2/2020
DIMENSIONS: INCHES (MILLIMETERS)				DRAWN	W. SPIVEY 9/2020
				CHECKED	R. JONES 9/2020
				REV A	R. JONES 12/2021
		COMMENTS:		REV A: NO CHANGES	
		DO NOT SCALE DRAWING			

**Insurance Institute for Highway Safety**  
 988 Dairy Rd, Ruckersville, VA 22968 (434) 985-4600

**BALLAST PLATE  
 HANDLES LONG**

SCALE: 1:1 | WEIGHT: 0.15 KG | SHEET 60 of 66

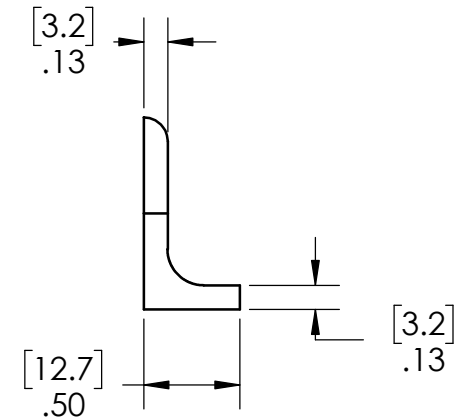
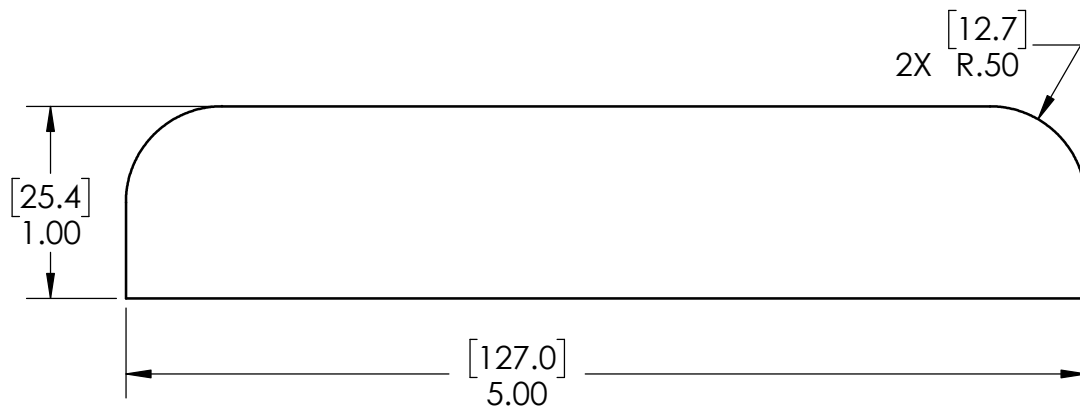
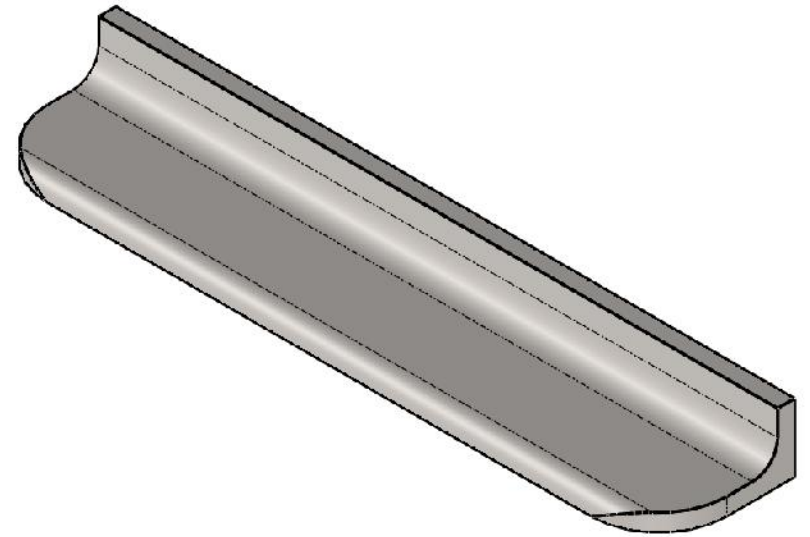
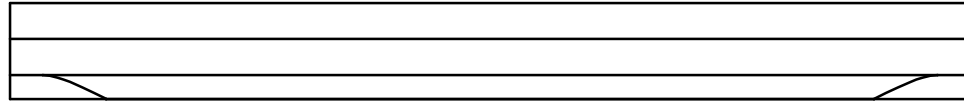

FROM 1X1X.125 ANGLE

**DRAWING NOT  
FOR PRODUCTION USE**

<b>A4</b>	THIRD ANGLE PROJECTION	<b>UNLESS OTHERWISE SPECIFIED:</b>		NAME	DATE
		MATERIAL	DESIGN/ENGR	C. O'BRIEN	2/2020
DIMENSIONS: INCHES (MILLIMETERS)		<b>ASTM A36</b>	DRAWN	W. SPIVEY	9/2020
			CHECKED	R. JONES	9/2020
			REV A	R. JONES	12/2021
			COMMENTS:	REV A: NO CHANGES	
		DO NOT SCALE DRAWING			

Insurance Institute for Highway Safety  
988 Dairy Rd, Ruckersville, VA 22968 (434) 985-4600

**BALLAST PLATE  
HANDLES SHORT**

SCALE: 1:1 | WEIGHT: 0.11 KG | SHEET 61 of 66

[1219.2]  
48.00  
[1197.0]  
47.13

6X  $\phi$  .56 [14.3] THRU

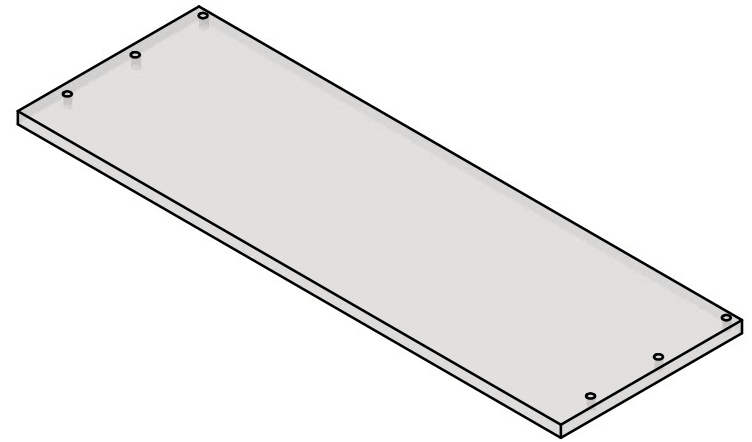

[22.2]  
.88  
[.0]  
0

[.0]  
0

[12.7]  
.50

[165.1]  
6.50

[317.5]  
12.50

[406.4]  
16.00

[25.4]  
1.00

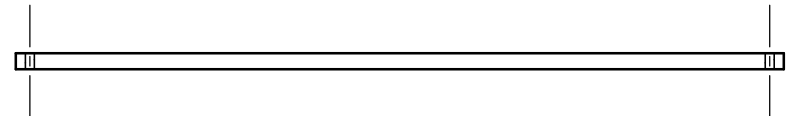

**DRAWING NOT FOR PRODUCTION USE**

<b>A4</b>	THIRD ANGLE PROJECTION	<b>UNLESS OTHERWISE SPECIFIED:</b>	NAME	DATE
		MATERIAL	DESIGN/ENGR	
DIMENSIONS: INCHES (MILLIMETERS)		<b>ASTM A36</b>	C. O'BRIEN	2/2020
			DRAWN	W. SPIVEY
			CHECKED	R. JONES
			REV A	R. JONES
			COMMENTS:	12/2021
			REV A: NO CHANGES	
		DO NOT SCALE DRAWING		

**Insurance Institute for Highway Safety**  
988 Dairy Rd, Ruckersville, VA 22968 (434) 985-4600

**BALLAST WEIGHT PLATE FRONT**

SCALE: 1:12 | WEIGHT: 99 KG | SHEET 62 of 66

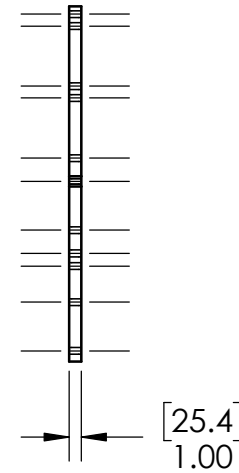
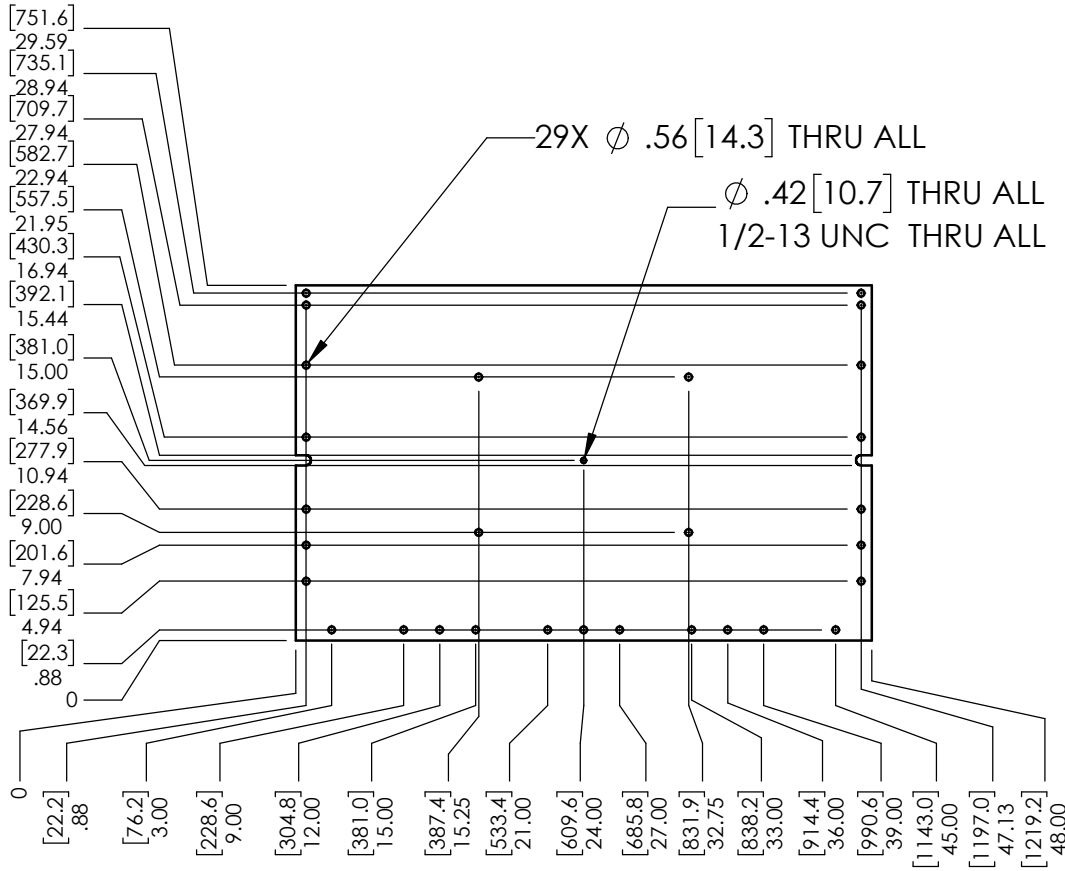
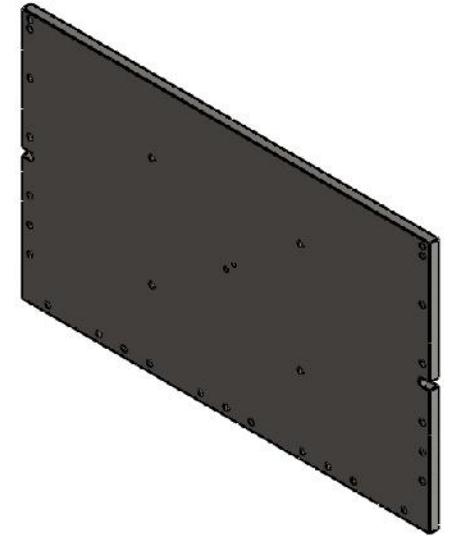
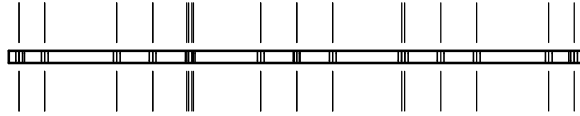

**DRAWING NOT  
FOR PRODUCTION USE**

A4	THIRD ANGLE PROJECTION	UNLESS OTHERWISE SPECIFIED:	NAME	DATE
		MATERIAL	DESIGN/ENGR	C. O'BRIEN 2/2020
DIMENSIONS: INCHES (MILLIMETERS)		ASTM A36	DRAWN	W. SPIVEY 9/2020
			CHECKED	R. JONES 9/2020
			REV A	R. JONES 12/2021
			COMMENTS:	
			REV A: NO CHANGES	
		DO NOT SCALE DRAWING		

Insurance Institute for Highway Safety		
988 Dairy Rd, Ruckersville, VA 22968 (434) 985-4600		
<b>BALLAST PLATE REAR</b>		
SCALE: 1:16	WEIGHT: 181.5 KG	SHEET 63 of 66

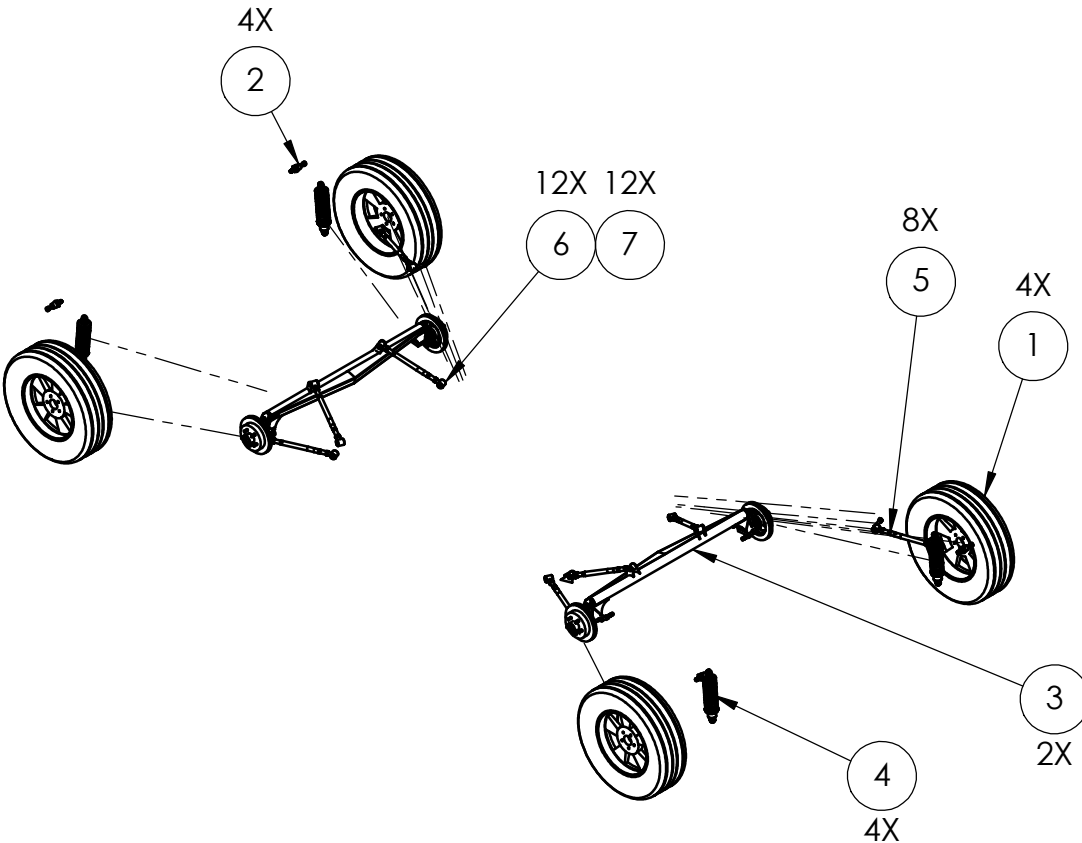

	PART NUMBER	QTY.
1	245/70R-17 TIRE AND WHEEL	4
2	SHOCK UPPER SPACER MOUNT	4
3	3500# 4" DROP 66" HUB-HUB AXLE W/ 10" DISC BRAKES	2
4	24159901 SHOCK 59120400 400 LBS/IN SPRING FRONT 59120300 300 LBS/IN SPRING REAR	4
5	14" CONTROL ARM	8
6	HBOLT 0.6250-11X3X1.5-N	2
7	HNUT 0.6250-11-D-N	2

SEE SHEET 66 FOR PARTS LISTINGS

**DRAWING NOT FOR PRODUCTION USE**

<b>A4</b>	THIRD ANGLE PROJECTION	<b>UNLESS OTHERWISE SPECIFIED:</b>	NAME	DATE	
			DESIGN/ENGR	C. O'BRIEN	2/2020
DIMENSIONS: INCHES (MILLIMETERS)		MATERIAL	DRAWN	W. SPIVEY	9/2020
		<b>N/A</b>	CHECKED	R. JONES	9/2020
			REV <b>A</b>	R. JONES	12/2021
			COMMENTS:		
			REV <b>A</b> :		
		DO NOT SCALE DRAWING			

**Insurance Institute for Highway Safety**  
988 Dairy Rd, Ruckersville, VA 22968 (434) 985-4600

**ADD-IN PARTS**

SCALE: 1:48    WEIGHT: N/A    SHEET 64 of 66



ITEM NO.	PART NUMBER	QTY.
1	THREE QUARTER X FIVE EIGHTHS ROD END	2
2	14" TUBE	1
3	0.75-16 LH JAM NUT	1
4	0.75-16 RH JAM NUT	1

SEE SHEET 66 FOR PARTS LISTINGS

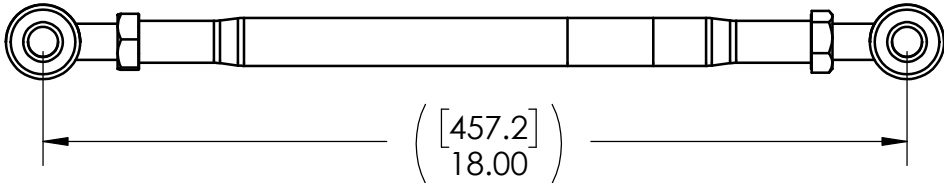
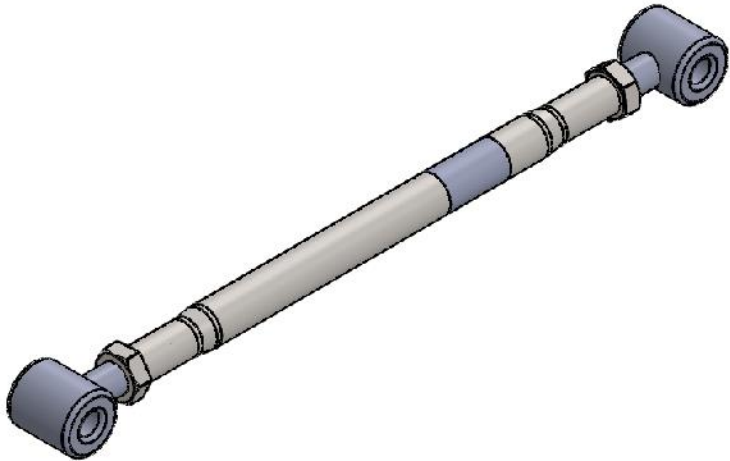
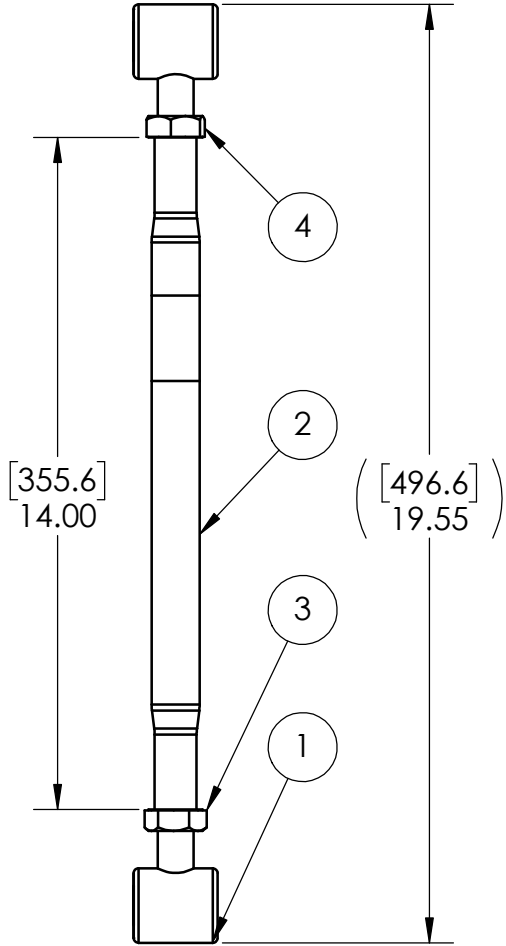

**DRAWING NOT FOR PRODUCTION USE**

<b>A4</b>	THIRD ANGLE PROJECTION	UNLESS OTHERWISE SPECIFIED:	NAME	DATE
		MATERIAL	DESIGN/ENGR	C. O'BRIEN 2/2020
DIMENSIONS: INCHES (MILLIMETERS)		N/A	DRAWN	W. SPIVEY 9/2020
			CHECKED	R. JONES 9/2020
			REV A	R. JONES 12/2021
			COMMENTS:	
		DO NOT SCALE DRAWING	REV A: DELETE 22" CONTROL ARM SHEET	

Insurance Institute for Highway Safety  
988 Dairy Rd, Ruckersville, VA 22968 (434) 985-4600

**14" CONTROL ARM**

SCALE: 1:4 WEIGHT: 1.2 KG SHEET 65 of 66

**IHS Side Impact Cart with Suspension Purchased Parts List**

Qty	Vendor Part Number	Manufacturer	Description	Dimensions/Options	Vendor	Vendor Address	Vendor Phone	Vendor Website
2		Dexter Axle	3,500 lb. Kodiak Hydraulic Disk 4" Drop Standard Spring Dexter Trailer Axle	66 in. Hub Face - Hub Face	Southwest Wheel	4809 S. Westmoreland Rd, Dallas, Tx 75237	214-631-0200	trailerpart.com
	2/H-10-DDD		Included Kodiak Brake Kit	10" Rotors				
4		Various	Radial Tire	245/70R-17				
4	VN2157765	American Racing	VN215 Classic Torq Thrust II 1 Piece	17x7, 5x4.5 bolt pattern, 4 in. backspace	Summit Racing	P.O. Box 909, Akron, OH 44309-0909	800-230-3030	summitracing.com
20	611-292	Dorman Products	Wheel Nut, Dometop	1/2-20, 13/16 Hex, 1.5 in length	Auto parts retailer			
2			Triangulated 4 Link Rear Suspension Weld On Bracket Kit	Detailed in sheets 28-30, 32	Typically available from eBay vendors, Helix Suspension Steering Brakes, Ridetech, Airmaxxx, Speedway Motors, Summit Racing. Some offer brackets separately.			
4	24139901	Ridetech	Universal HQ Series Coilover Single Adjustable	11.5" Ride Height, 3.6" Stroke, 1.7" Eye Mount	Ridetech	350 S. St. Charles St, Jasper, IN 47546	812-481-4787	ridetech.com
4	24159901	Ridetech	Universal HQ Series Coilover Single Adjustable	14.5" Ride Height, 5.2" Stroke, 1.7" Eye Mount	Ridetech	350 S. St. Charles St, Jasper, IN 47546	812-481-4787	ridetech.com
2	59080550	Ridetech	8" Coilover Spring	2.5" ID, 550 lb/in rate	Ridetech	350 S. St. Charles St, Jasper, IN 47546	812-481-4787	ridetech.com
2	59120400	Ridetech	12" Coilover Spring	2.5" ID, 400 lb/in rate	Ridetech	350 S. St. Charles St, Jasper, IN 47546	812-481-4787	ridetech.com
2	59080450	Ridetech	8" Coilover Spring	2.5" ID, 450 lb/in rate	Ridetech	350 S. St. Charles St, Jasper, IN 47546	812-481-4787	ridetech.com
2	59120300	Ridetech	12" Coilover Spring	2.5" ID, 300 lb/in rate	Ridetech	350 S. St. Charles St, Jasper, IN 47546	812-481-4787	ridetech.com
8	91008036	Speedway	Forged Rod End	3/4-16 RH Thread	Speedway Motors, Inc.	340 Victory Ln, Lincoln, NE 68528	402-323-3200	speedwaymotors.com
8	91008037	Speedway	Forged Rod End	3/4-16 LH Thread	Speedway Motors, Inc.	340 Victory Ln, Lincoln, NE 68528	402-323-3200	speedwaymotors.com
8	1063414	AFCO	Swedged Steel Tube	14" long, 3/4-16 thread, black	Speedway Motors, Inc.	340 Victory Ln, Lincoln, NE 68528	402-323-3200	speedwaymotors.com
8		Various	Jam Nut	3/4-16 RH Thread				
8		Various	Jam Nut	3/4-16 LH Thread				
4	91636010	Speedway	Coilover Shock Mount Bolt w/ Support Collar	4.5" long, 5/8-18 thread, 5/8 stud diameter	Speedway Motors, Inc.	340 Victory Ln, Lincoln, NE 68528	402-323-3200	speedwaymotors.com
2	H381272	Dorman Products	Frame to Axle Brake Hose w/ Tee		Auto parts retailer			
4	J0937884	Crown Automotive	Axle to Caliper Brake Hose	16", 3/8-24 Inv. Flare male-female	Summit Racing	P.O. Box 909, Akron, OH 44309-0909	800-230-3030	summitracing.com
6			Brake Hose Retaining Clip		The Stop Shop	5775 Zarley St. Suite B, New Albany, OH 43054	614-557-3442	thestopshop.com
1			3/16" Copper Nickel Brake Line Kit w/ Fittings	25 ft	The Stop Shop	5775 Zarley St. Suite B, New Albany, OH 43054	614-557-3442	thestopshop.com
1			3/16" Stainless Brake Line Protector	16 ft	The Stop Shop	5775 Zarley St. Suite B, New Albany, OH 43054	614-557-3442	thestopshop.com
			3/16" Brake Line Clip		The Stop Shop	5775 Zarley St. Suite B, New Albany, OH 43054	614-557-3442	thestopshop.com
16		Various	Hex Bolt	0.625-11 X 3 X 1.5 - N				
4		Various	Hex Bolt	0.5-20 C2.5 X 1.25 - N				
14		Various	Hex Bolt	0.375-16 X 2 X 1 - N				
4		Various	Hex Bolt	0.3125-18 X 1 X 0.875 - N				
16		Various	Hex Nut	0.625-11 - D - N				
4		Various	Hex Nut	0.5-20 - D - N				
8		Various	Screw	0.75-16 X 1.5 X 1.5 -HX - N				
28		Various	Flat Washer	0.375				
4		Various	Flat Washer	0.3125				

	NAME	DATE
DESIGN/ENGR		
DRAWN	R JONES	9/2020
CHECKED		
REV A	R JONES	12/2021
COMMENTS:		
REV A: UPDATE SHOCKS, SPRINGS, 14" SWEDGE TUBE QTY		

**Insurance Institute for Highway Safety**  
988 Dairy Rd, Ruckersville, VA 22968 (434) 985-4600

**VENDOR & SUPPLY LIST**